



M10HCT-A-TNC

L1-L2-L5 ACTIVE GNSS ANTENNA
Part #: 100-00282-01



Description

M10HCT-A-TNC is a L1-L2-L5 active antenna solution intended to cover all GPS, Galileo, Glonass, BeiDou bands including L-Band correction services coverage. Low profile RHCP, wide band antenna is ideal solution for high-precision applications, such as autonomous vehicle navigation, smart survey devices, and maritime positioning. This antenna is built on proprietary Maxtena Helicore® technology. This technology provides exceptional pattern control, polarization purity and high efficiency in a very compact form factor. Low axial ratio ensures that the antenna captures RHCP signal well and mitigates the reflected LHCP signals. Antenna ensures high signal-to-noise ratio (SNR) and GNSS signal tracking from all elevation angles in all types of environments. The antenna is ground plane independent and comes in three versions: Screw mount, magnet mount and embedded. The embedded version is custom tuned to the applications enclosure.



Active Circuit Performance

Parameter	Specification
Conducted gain	34.5 dB @ upper band 35.4 dB @ lower band
Noise figure	3.1 dB @ upper band 2.9 dB @ upper band
Voltage	2.3 V - 16 V
Current	40 mA (max.)
Out of band rejection	≥ 70 dB @ ≥ 1700 MHz ≥ 35 dB @ ≥ 1650 MHz ≥ 35 dB @ 1450 - 1520 MHz ≥ 60 dB @ 1350 - 1450 MHz ≥ 80 dB @ ≤ 1125 MHz
Group delay variation	< 3 ns @ L1 < 4 ns @ L2 < 22 ns @ L5
EMI Immunity Out of Band	30 kV
Output P1dB	12.5 dBm @ upper band 13.1 dBm @ lower band

Features

- Full GPS, Galileo, Glonass, BeiDou bands coverage including L-Band correction services coverage
- Low Axial Ratio
- Low Noise Figure
- Ground plane independent
- Low power consumption
- Low phase center variation over azimuth and elevation and among different samples
- Rugged IP67 rating
- RoHs compliant
- Automotive grade electronics

Applications

- UAV/Drones
- Unmanned Ground Vehicles (UGV)
- Unmanned Systems
- High Precision Navigation
- Military & Security
- Agriculture & FarmTech
- Marine systems



ppm GmbH
Grube 39a
82377 Penzberg
Germany

Tel: +49 (0) 88 56 8 03 09 80
Fax: +49 (0) 88 56 8 03 09 88

info@ppmgbh.com
www.ppmgbh.com



Maxtena Inc.
20310 Seneca Meadows
Parkway, Suite A Germantown
MD 20876
1-877-629-8362
info@maxtena.com
www.maxtena.com



Passive antenna performance

Parameter	Specification
Frequency Range	1164 - 1300 MHz 1539 - 1610 MHz
Peak gain	3.4 dBic @ upper band 3.3 dBic @ lower band
Peak efficiency	80 % @ upper band 75 % @ lower band
Axial Ratio	0.5 dB (max.) @ zenith
Polarization	RHCP
Beamwidth	120°

Mechanical specification

Parameter	Specification
Antenna Dimensions	Ø80 x 40 mm
Weight	114 g
Operating Temperature	-40 °C to 85 °C
Mounting Type	Connector Mount
Connector	TNC
Radome/Color	Black
Housing material	ABS/PC
Certificates	IP67

Antenna Characteristics

Return Loss

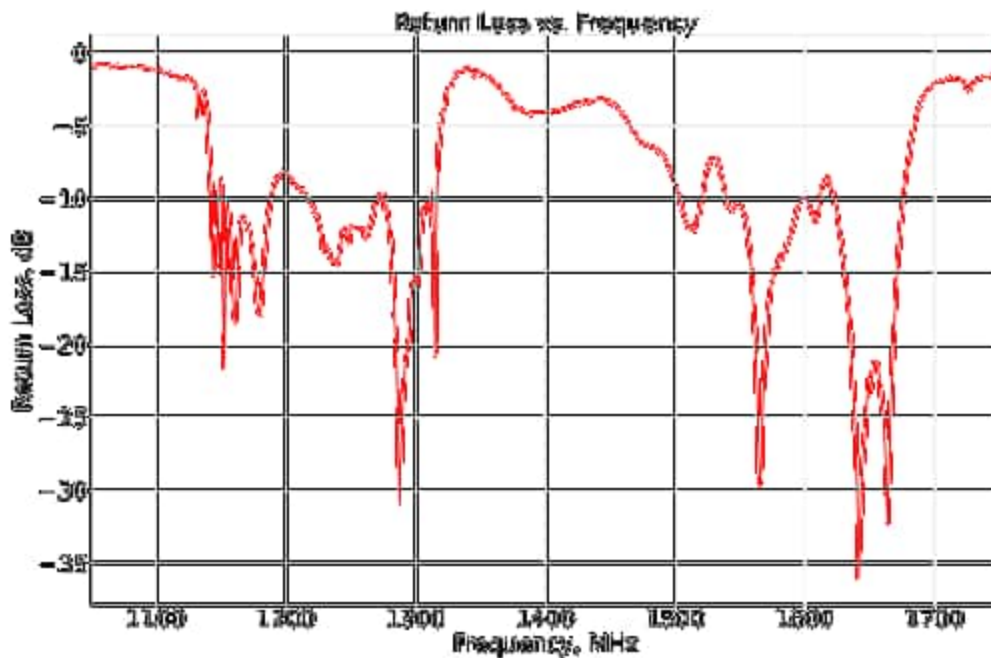

VSWR

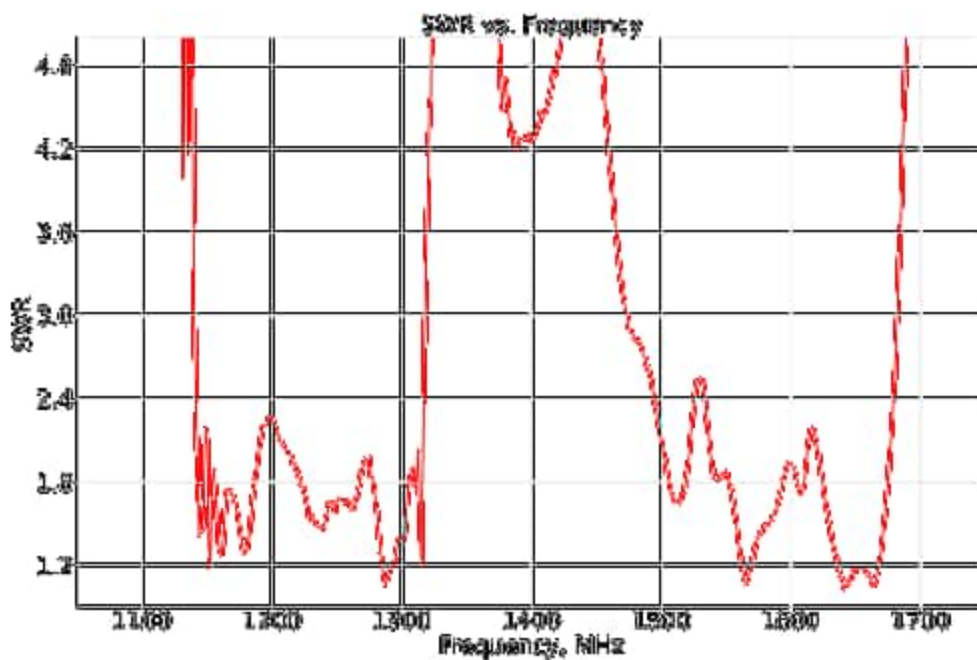

Efficiency

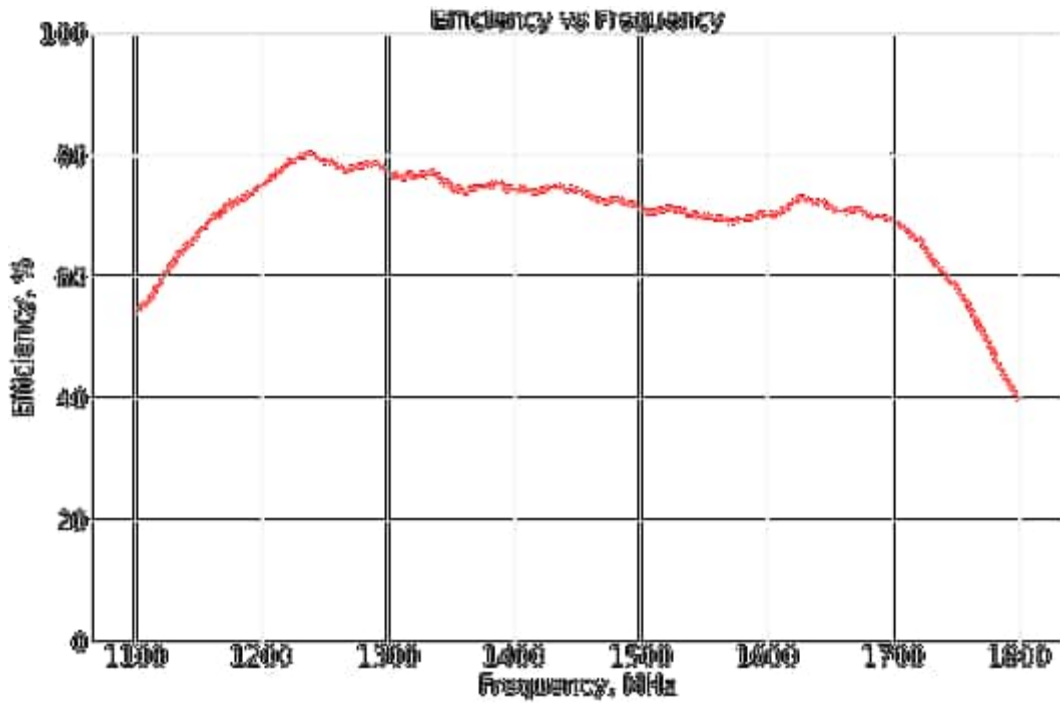

Gain

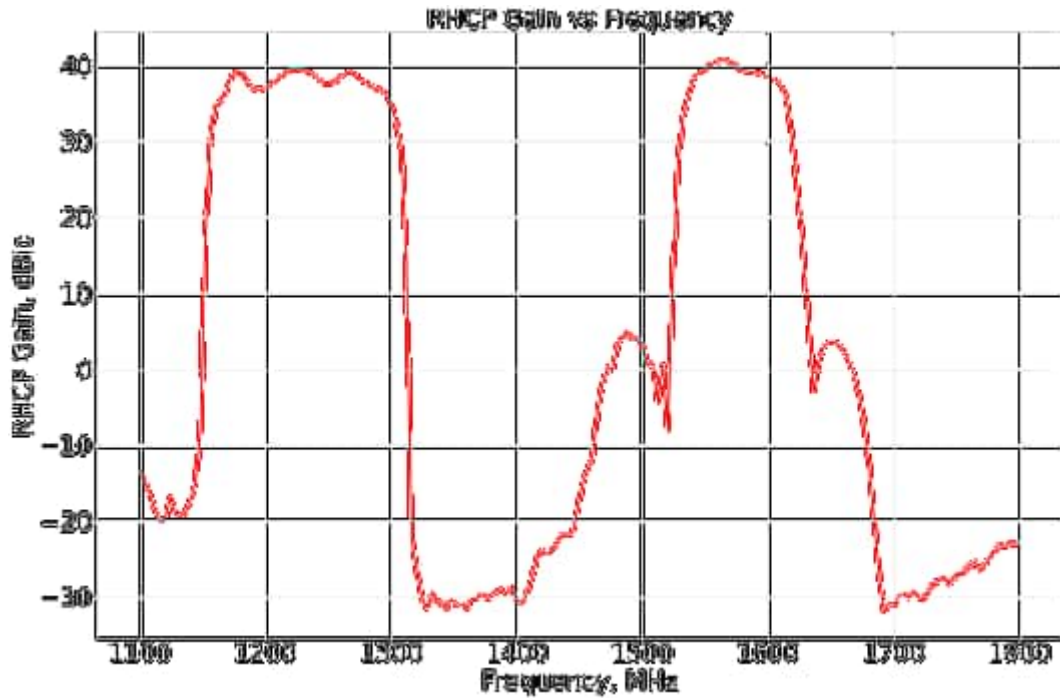

2D Radiation Patterns

Maxtena's M10HCT-A-TNC has unique features that make it the best option for high-accuracy GNSS applications. Full hemispherical coverage is achieved by an exceptionally large 3 dB beamwidth, ensuring full view of sky and satellites in lower elevation angles. Highly symmetric radiation pattern guarantees there will be no direction of weak reception or blind spots.

L1 band

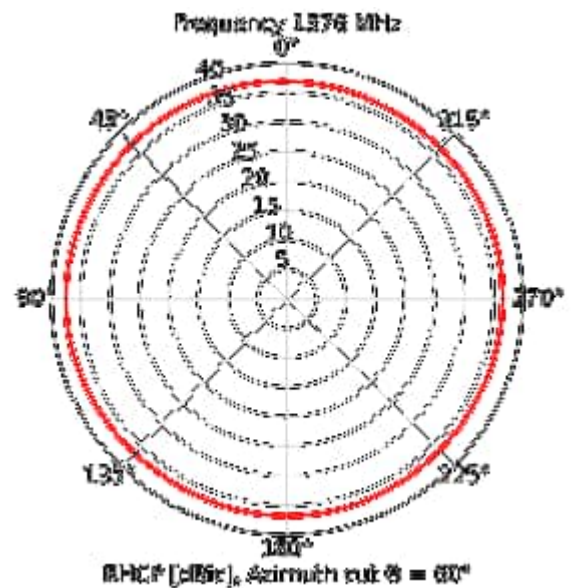
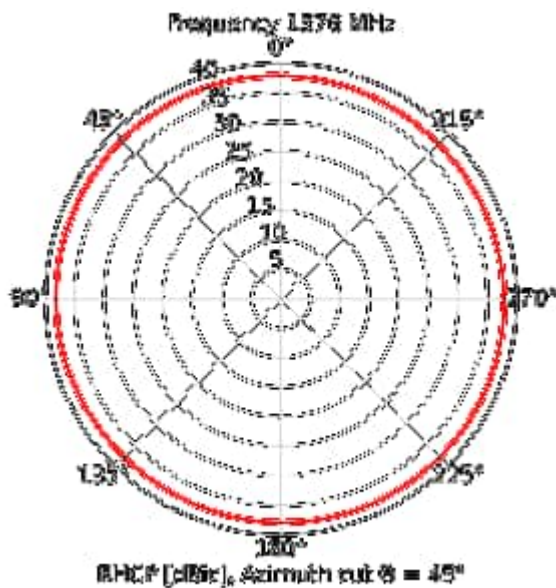
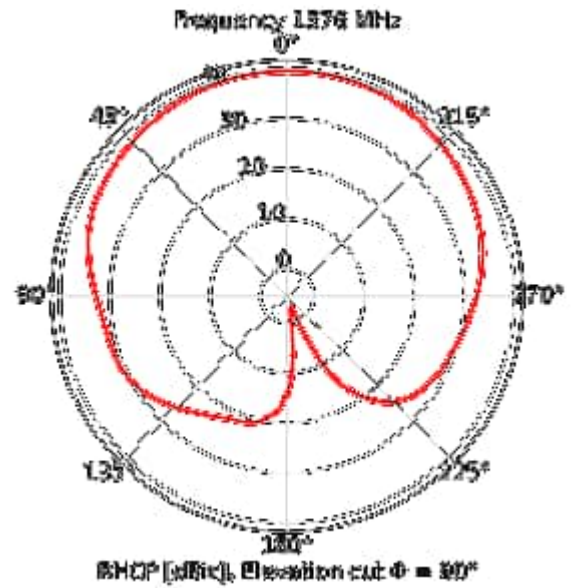
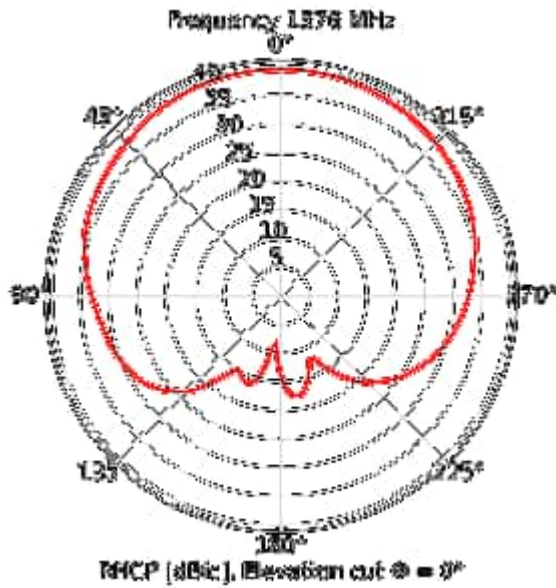

L2 band

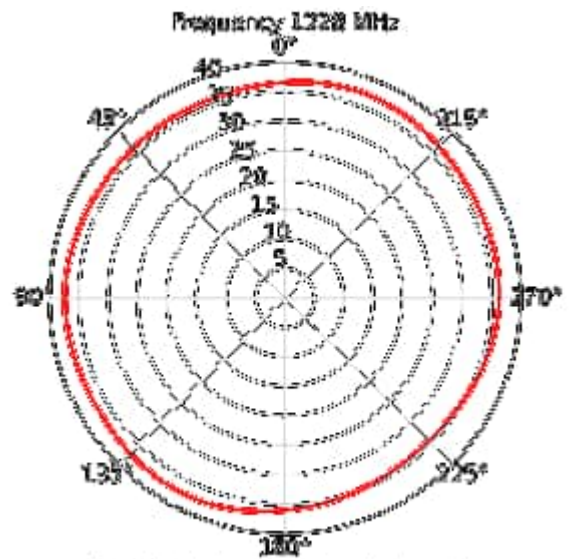
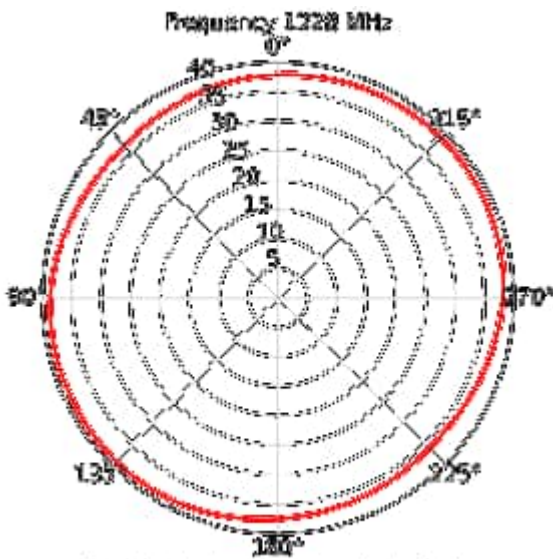
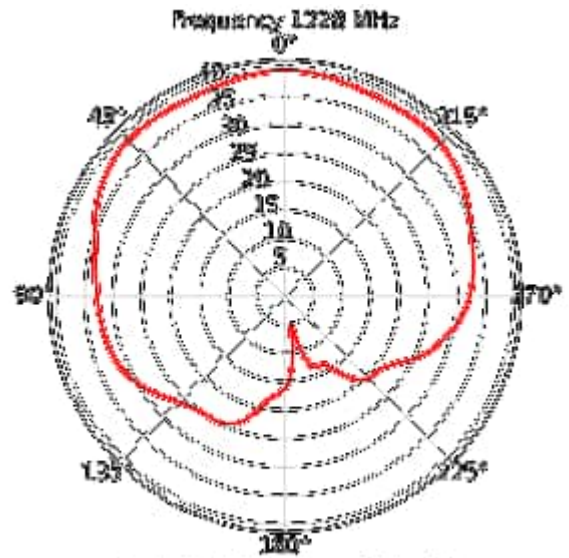
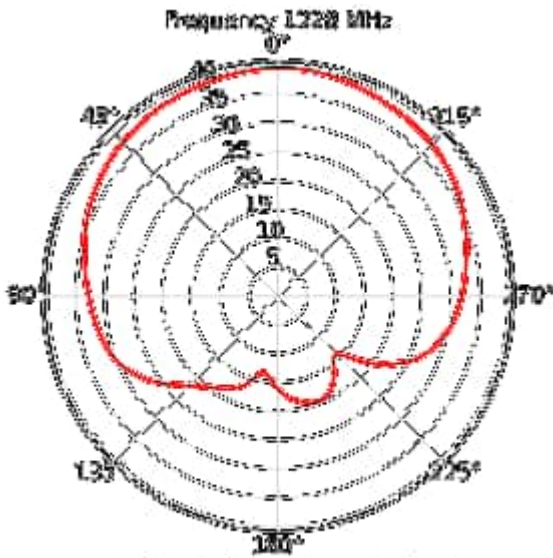

L5 band

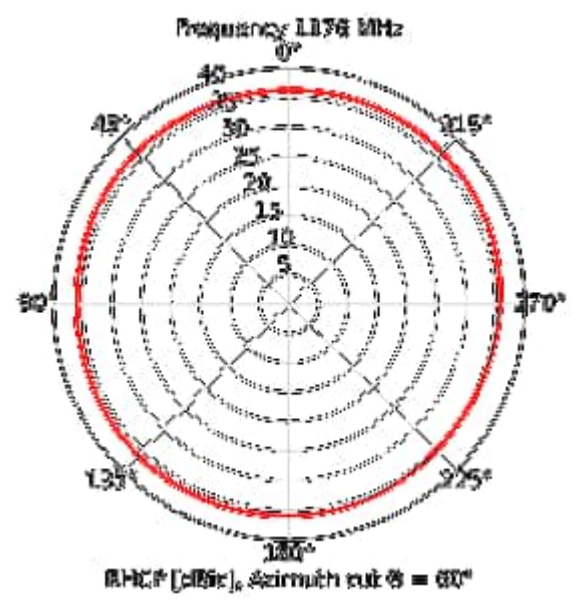
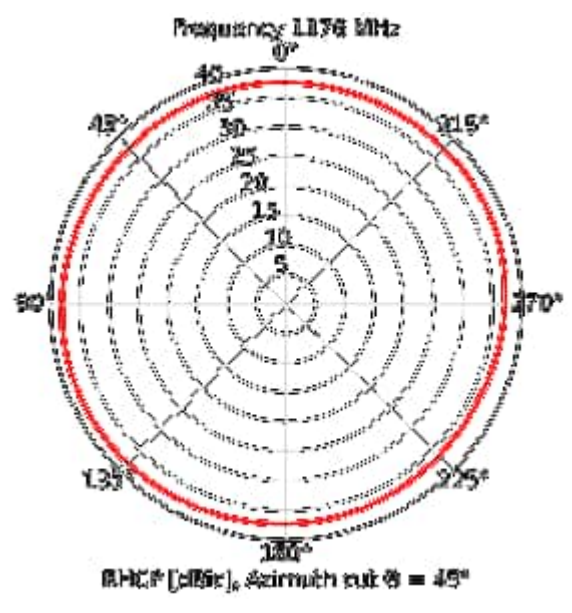
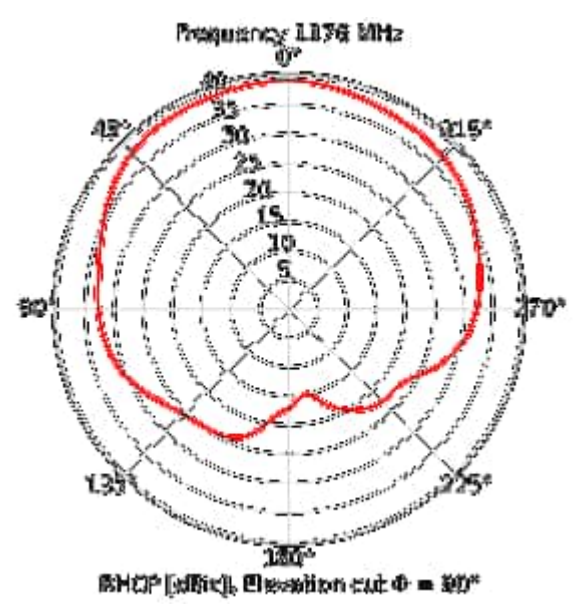
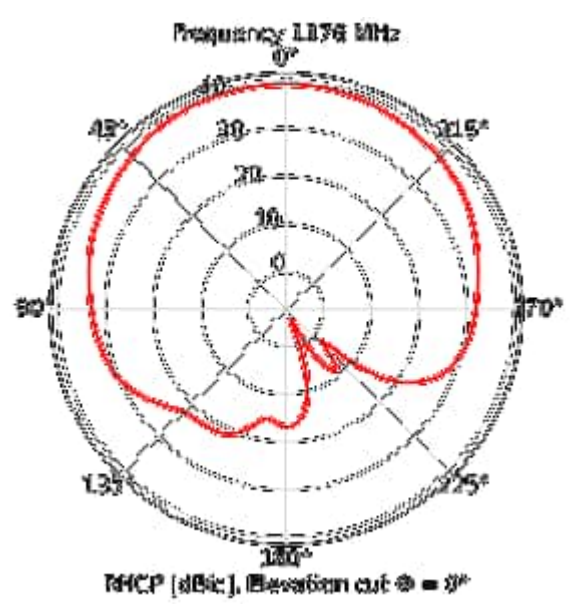

3D Radiation Patterns

L1 band

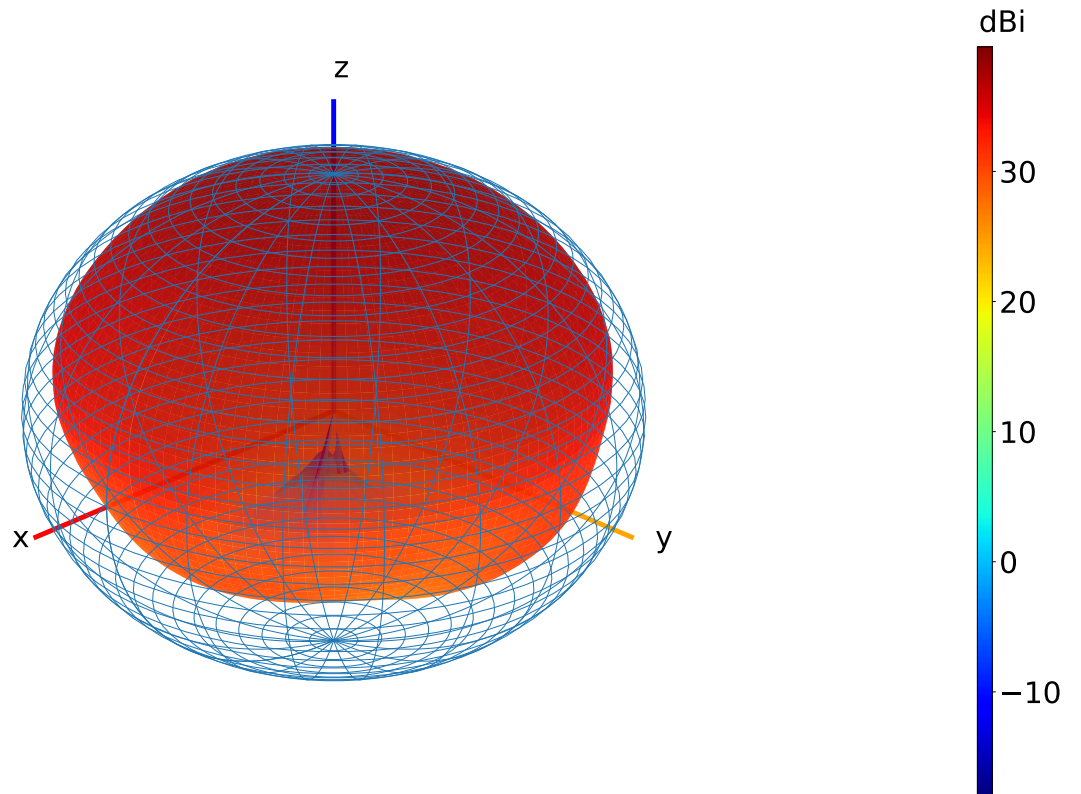

L2 band

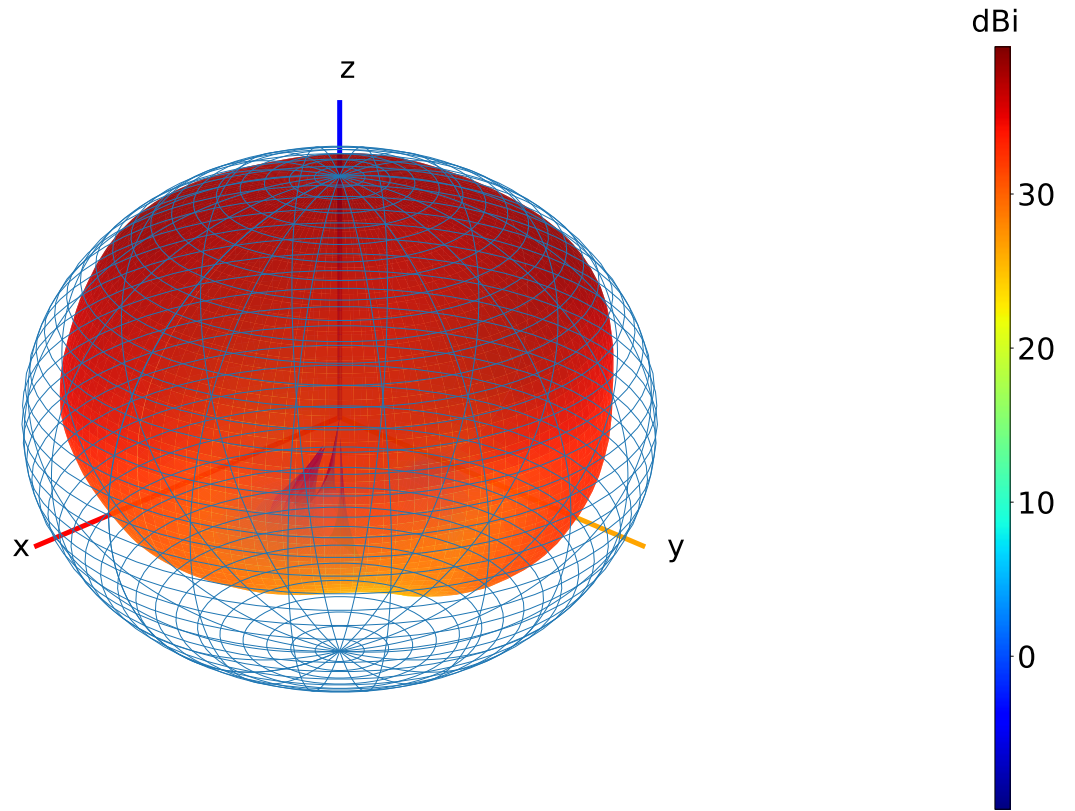

L5 band

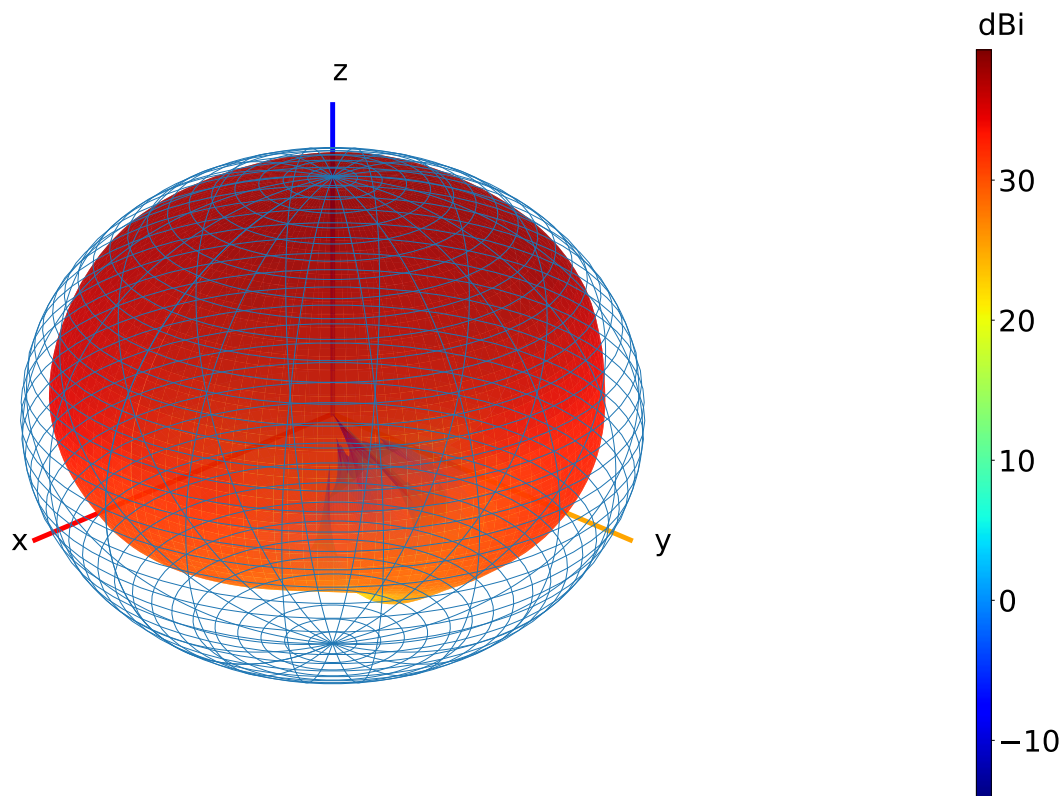

Axial Ratio

Axial Ratio is a very important parameter for high-accuracy GNSS applications. Ideally GNSS signals travel directly from the GNSS satellite to the receiver antenna. But buildings, trees, water, and road surfaces can cause GNSS signals reflection. Reflected signals change from right hand circular polarization to left hand circular polarization. A low axial ratio at the zenith and other elevation angles ensures multipath error is mitigated.

L1 band

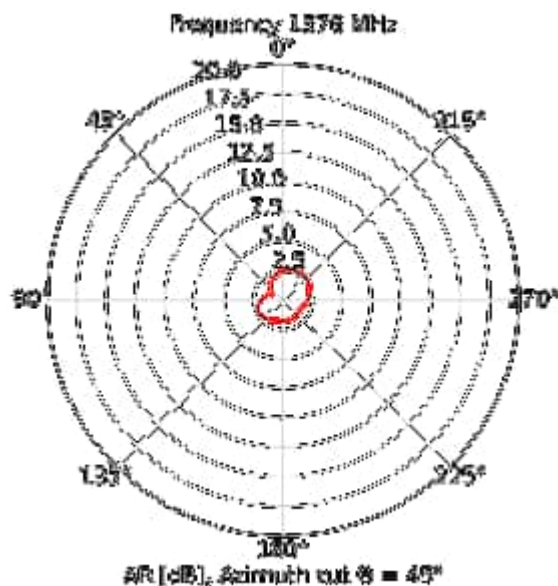
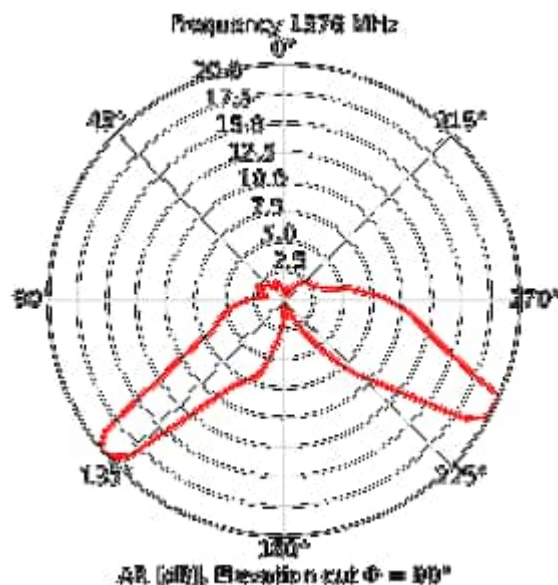
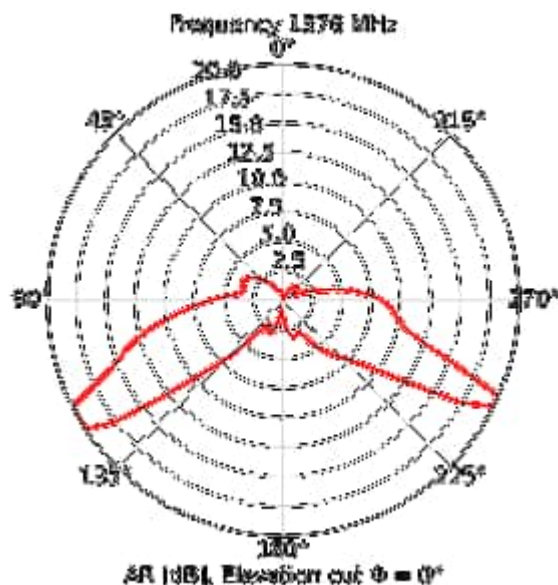

L2 band

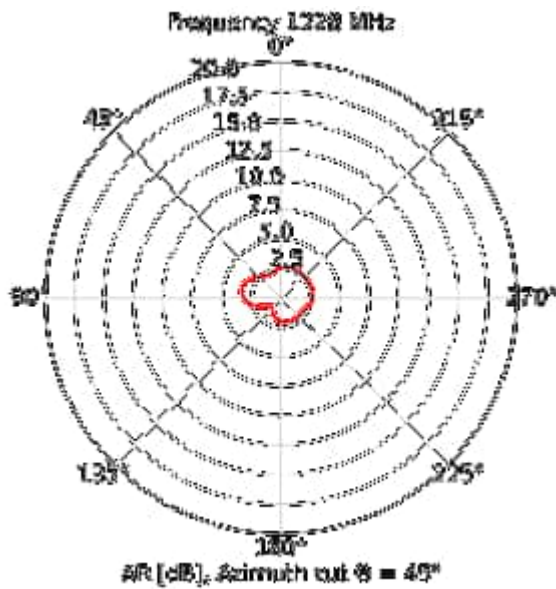
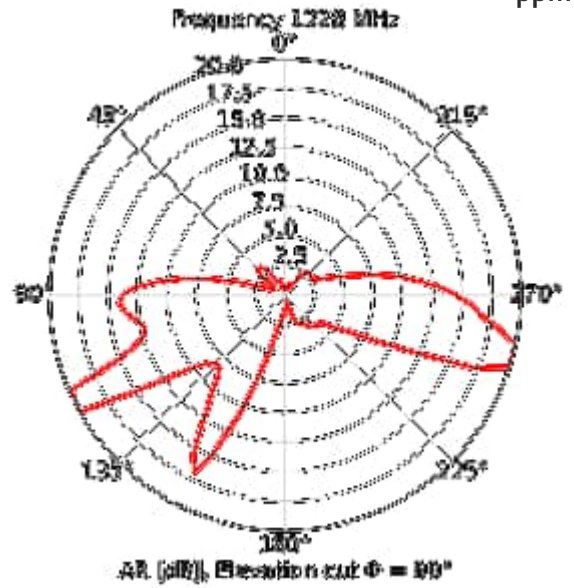
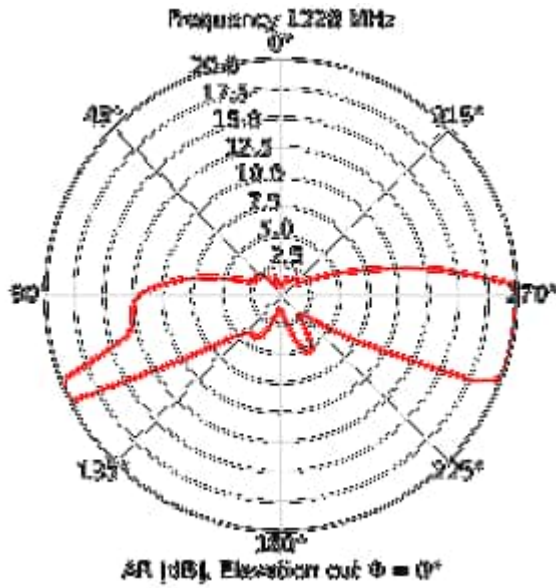

L5 band

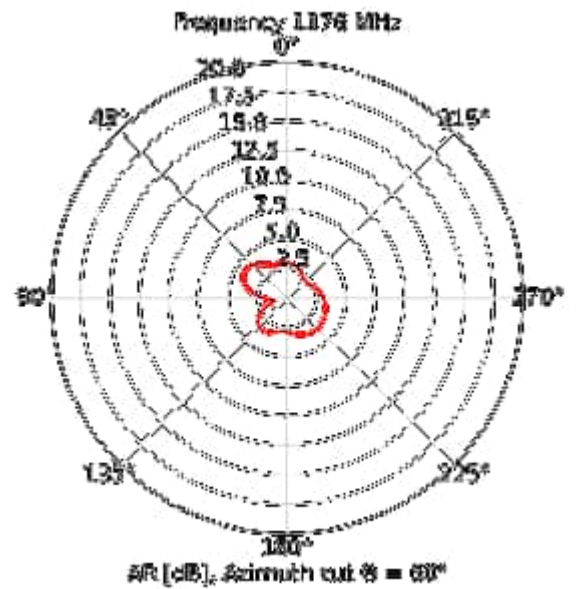
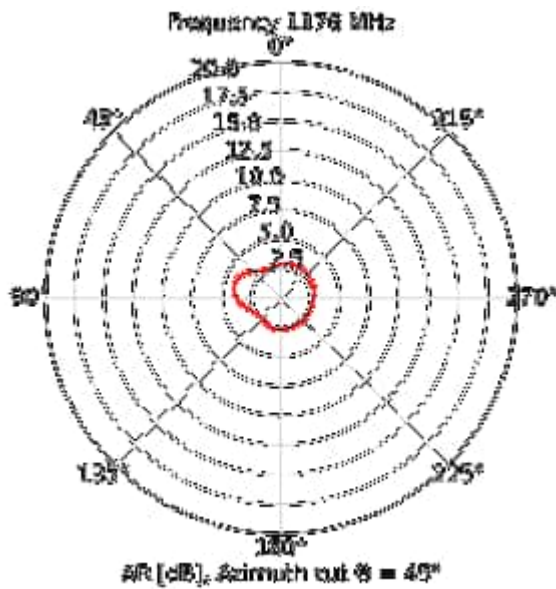
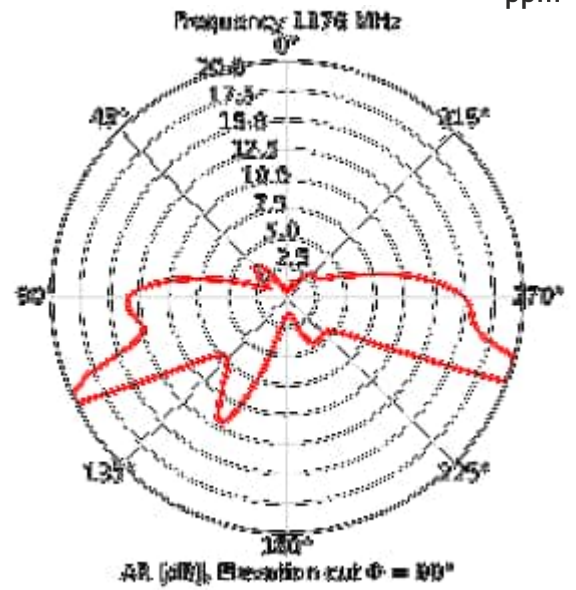
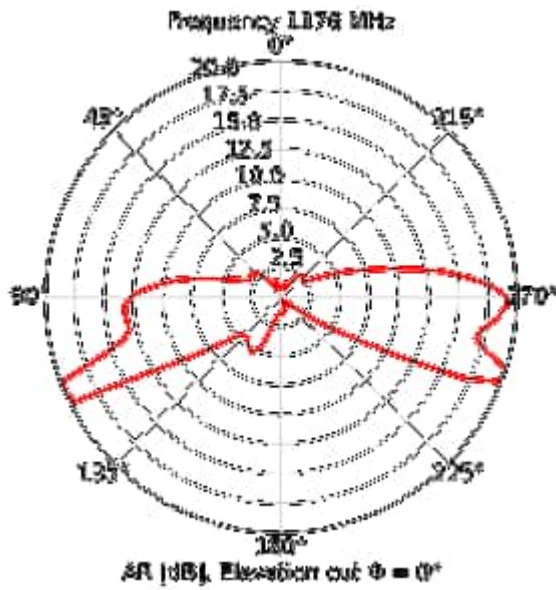

Phase center offset

Phase center offset and phase center variation values are important parameter in GPS precise positioning. Maxtena's M10HCT-A-TNC has minimal phase center variation over azimuth and elevation in all GNSS bands.

PCO	L1 band	L2 band	L5 band
x-axis	21.9 mm	20.2 mm	20 mm
y-axis	1.4 mm	-0.7 mm	0.8 mm
z-axis	14.2 mm	17.1 mm	17.5 mm

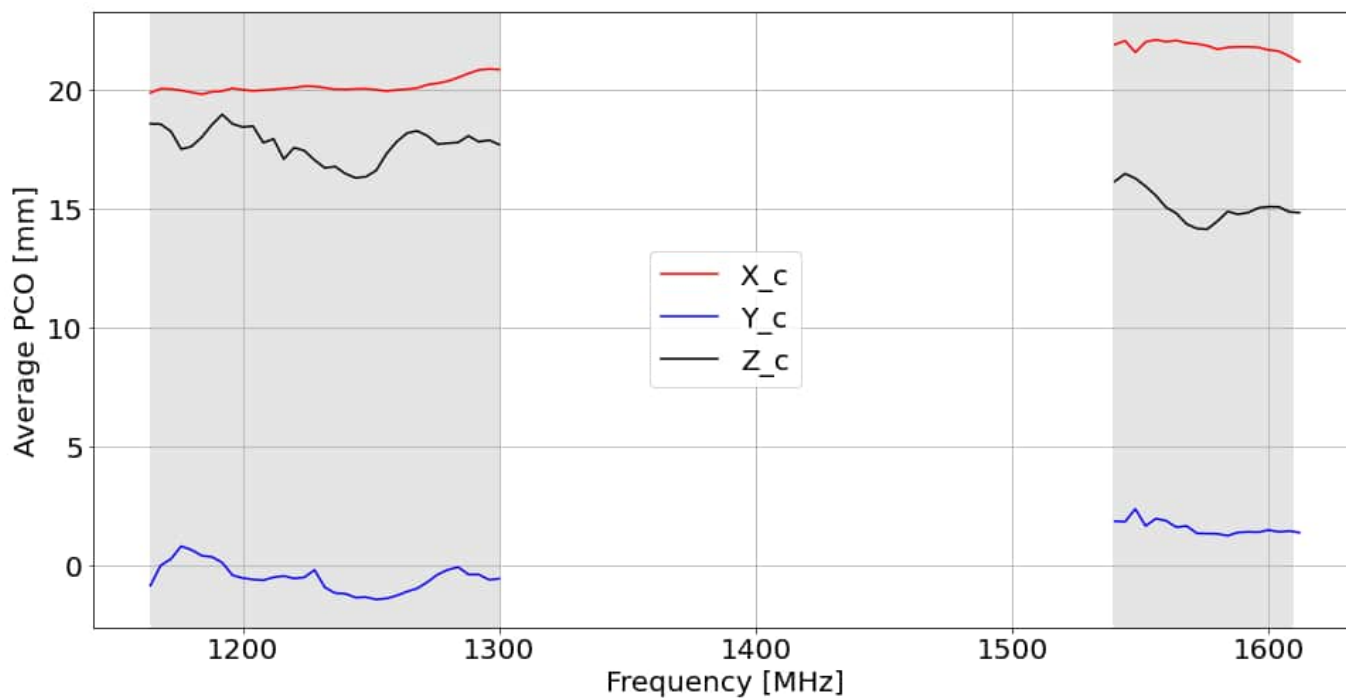

Phase center variation

L1 band

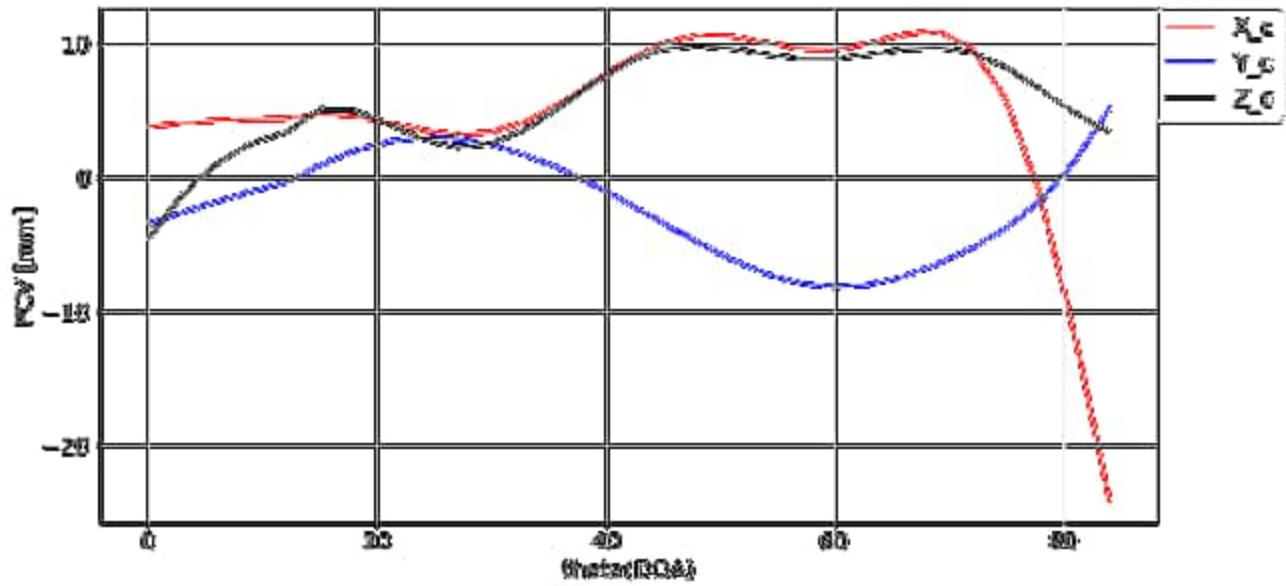

L2 band

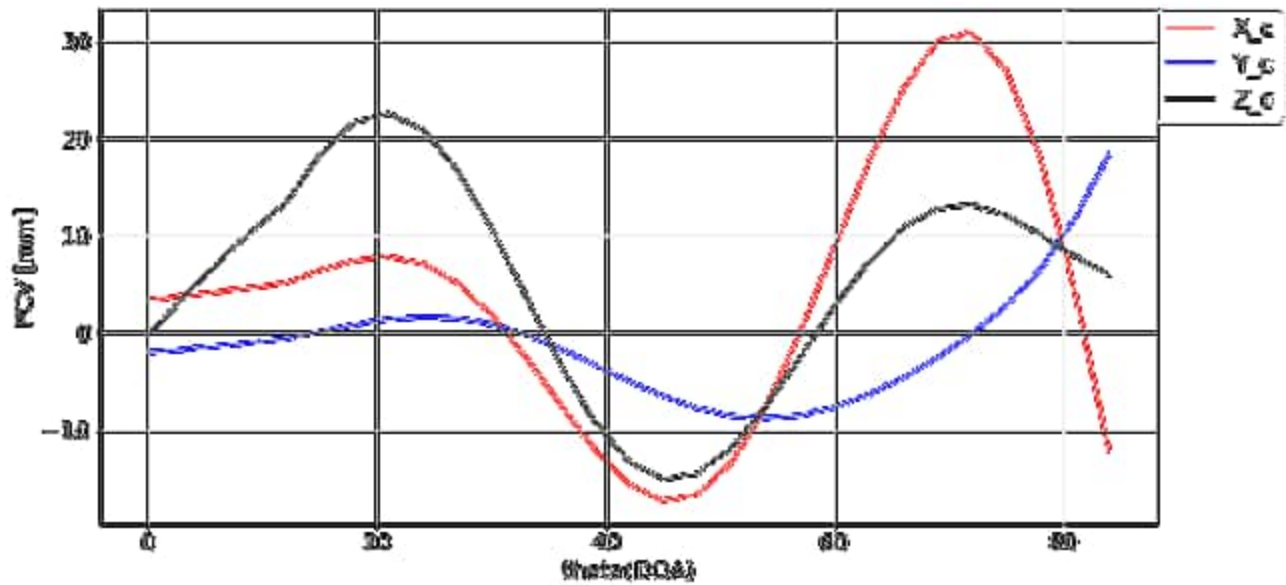

L5 band

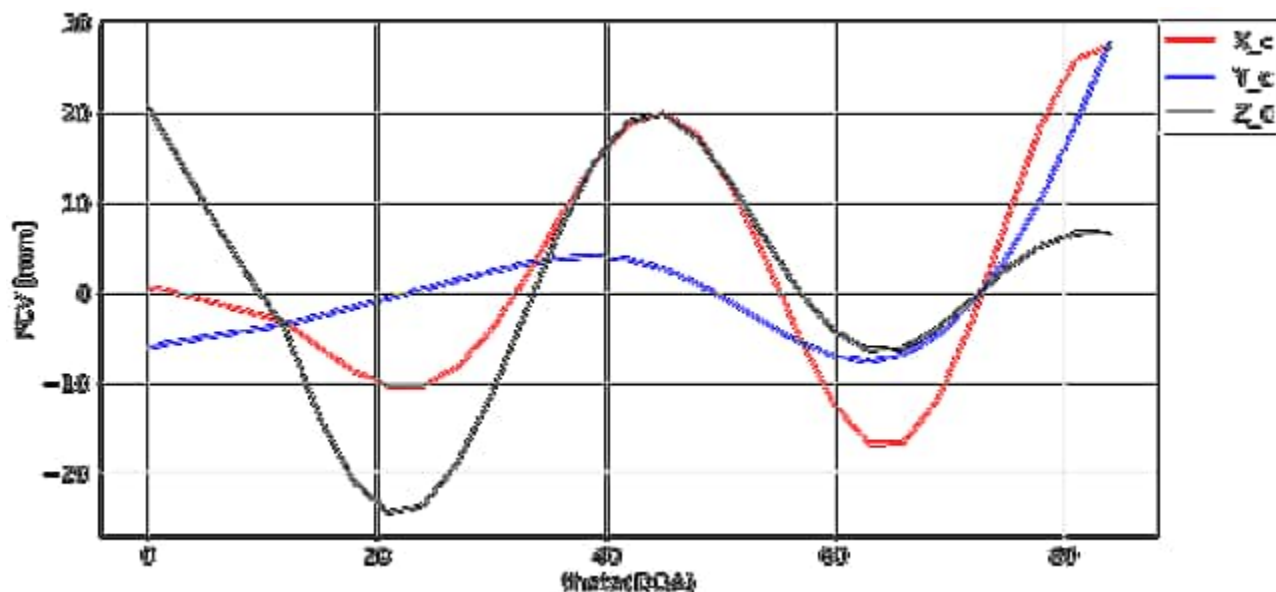

Rooftop Testing

For this test Maxtena used u-blox ZED-F9P receiver. Receiver was flashed with the latest firmware version. The test was performed in an open sky environment for 24 hours. Measurements were done without ground plane under the antenna.

Receiver features

- Receiver supports the GNSS and their signals as follows: GPS L1C/A L2C, GLO L1OF L2OF, GAL E1B/C E5b, BDS B1I B2I, QZSS L1C/A L1S L2C, SBAS L1C/A
- Horizontal position accuracy RTK= 0.01 m + 1 ppm CEP
- Vertical position accuracy RTK= 0.01 m + 1 ppm CEP
- Navigation update rate RTK up to 20 MHz

Positioning Accuracy					
Test Conditions	Correction Service	CEP (50 %)	DRMS (68 %)	2DRMS (95-98.2 %)	TTFF (sec)
Free space	RTK	0.66 cm	0.66 cm	1.3 cm	99.6

RTK Availability

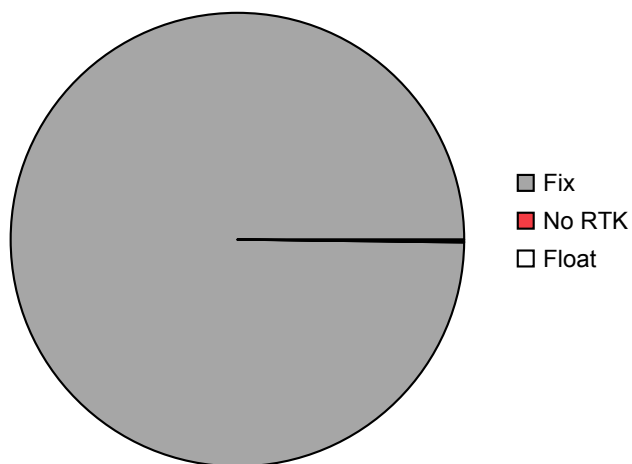

DRAWING REVISION HISTORY			
REV	DESCRIPTION	DATE	BY
1	INITIAL RELEASE	2022-09-25	MP

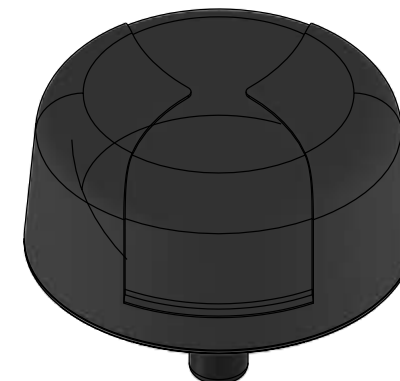
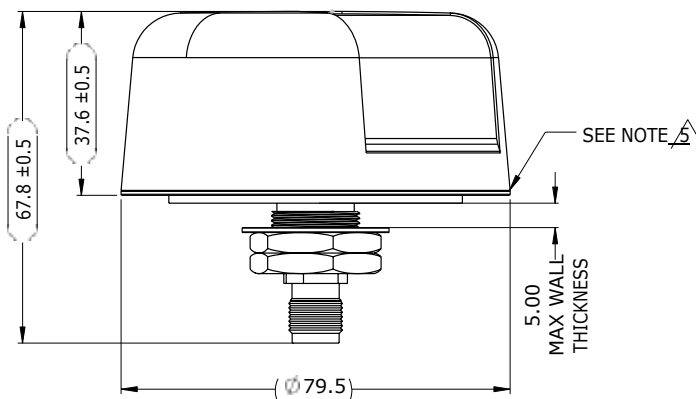
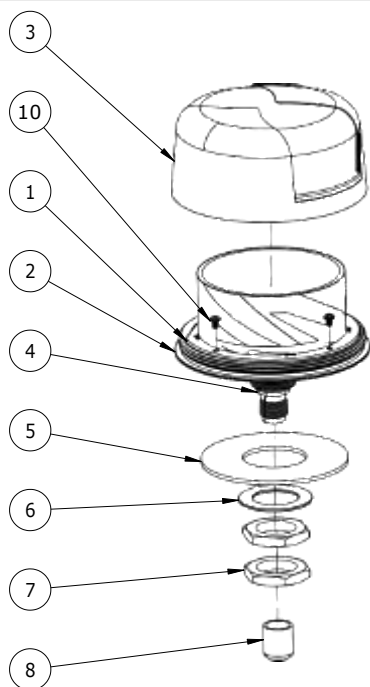

NOTES:

- ALL DIMENSIONS APPLY TO THE FINISHED PART. SEE CAD DATA FOR UNDIMENSIONED FEATURES.
- COSMETIC APPEARANCE IS TO BE IN ACCORDANCE WITH MAXTENA SPECIFICATION 454-00058-01, CLASS A.
- APPLY A 360 DEGREE BEAD OF ITEM 9 ON ITEM 8 TO THE LEADING THREADS, LEAVING THE FIRST THREAD FREE. FORCE THE MATERIAL INTO THE THREADS TO THOROUGHLY FILL THE VOIDS. TIGHTEN WITH A 15IN*LB INSTALLATION TORQUE.
- APPLY A 360 DEGREE CONTINUOUS BEAD OF ITEM 10 TO ITEM 1 AT THE SECOND THREAD PRIOR TO ASSEMBLY ITEM 7.
- ENSURE THAT NO GAPS EXIST BETWEEN ITEM 1 AND ITEM 7 AFTER ASSEMBLY.
- GLUED ASSEMBLY MUST MEET IP67 SPECIFICATION.
- REMOVE ANY EXCESS ADHESIVE AFTER ASSEMBLY.
- INSPECTION DIMENSION MARK AS (DIM). REFERENCE DIMENSIONS MARK AS (DIM).

ITEM 100-00282-01 REVISION HISTORY

REV	DESCRIPTION	DATE	BY
1	INITIAL RELEASE	2022-09-25	MP

PROPRIETARY AND CONFIDENTIAL

THE INFORMATION CONTAINED IN THIS DRAWING IS THE SOLE PROPERTY OF MAXTENA, INC. ANY REPRODUCTION IN PART OR AS A WHOLE WITHOUT THE WRITTEN PERMISSION OF MAXTENA, INC IS PROHIBITED.

ITEM 100-00282-01 BOM

ITEM NO	QTY REQD	PART NO	NOMENCLATURE OR DESCRIPTION
1	1	108-00064-01	PCB ASSEMBLY, TNC CONNECTOR, M10HCT-A-TNC PASSIVE
2	1	311-00032-01	BASE, TNC MOUNTING, SFX LP
3	1	312-00103-01	HOUSING, TNC MOUNT, SFX LP
4	1	104-00028-03	CABLE ASSY, TNC, RG178, CLIP
5	1	319-00024-01	GASKET, 26MM ID, 60MM OD, 1.6MM THICK
6	1	332-00003-01	WASHER, 19MM ID, 30MM OD, 1MM THICK, SST
7	2	321-00002-01	NUT, HEX, THIN HEAD, M18X1.0MM, SST
8	1	322-00001-01	DUST CAP, FOR 10MM OD, 12MM INSIDE HEIGHT
9	AR	303-00007-01	ADHESIVE, LOCTITE 243
10	4	328-00010-01	SCREW, MACHINE, PAN, #2-56, 1/8" LG, STEEL
11	AR	303-00003-01	ADHESIVE, DP810NS

UNLESS OTHERWISE SPECIFIED:	NAME	DATE
DIMENSIONS ARE IN MM	DRAWN	MP
TOLERANCES:	CHECKED	ZX
FRACTIONAL:	ENG APPR.	NPC
ANGULAR: MACH ± 5 BEND ±	MFG APPR.	
ONE PLACE DECIMAL ± .2	Q.A.	
TWO PLACE DECIMAL ± .20		
INTERPRET GEOMETRIC TOLERANCING PER:		
THIRD ANGLE PROJECTION		
DO NOT SCALE DRAWING		

MAXTENA, INC		
TITLE: 100-00282-01		
ASSEMBLY, TOP, M10HCT-A-TNC, TNC MOUNT		
SIZE	DWG. NO.	REV
B	117-00674-01	1
CAGE CODE: 5KQH7	SCALE: NONE	SHEET 1 OF 2

CAD MAINTAINED. CHANGES SHALL BE INCORPORATED BY THE DESIGN ACTIVITY.

