

STANDARD
MIL-STD
810G



Inertial Labs Single and Dual Antenna GPS-Aided Inertial Navigation Systems INS

The **Inertial Labs Single and Dual Antenna GPS-Aided Inertial Navigation System – INS** is a new generation of fully-integrated, combined GPS, GLONASS, GALILEO, QZSS, BEIDOU and L-Band navigation and high-performance strapdown system, that determines position, velocity and absolute orientation (Heading, Pitch and Roll) for any device on which it is mounted. Horizontal and Vertical Position, Velocity and Orientation are determined with high accuracy for both motionless and dynamic applications.



The Inertial Labs **INS** utilizes advanced single and dual antenna GNSS receiver, barometer, 3-axes each of calibrated in full operational temperature range precision Fluxgate magnetometers, Accelerometers and Gyroscopes to provide accurate Position, Velocity, Heading, Pitch and Roll of the device under measure. **INS** contains Inertial Labs new on-board sensors fusion filter, state of the art navigation and guidance algorithms and calibration software.

KEY FEATURES AND FUNCTIONALITY

- Affordable price
- Excellent accuracy in GPS-Denied environments (up to 0.05 % DT)
- Tactical-grade IMU + Fluxgate compass + Aiding data
- Support: ROS, LabVIEW, Waypoint Inertial Explorer, QINSy
- GPS, GLONASS, GALILEO, BEIDOU, SBAS, DGPS, RTK supported signals
- Tactical-grade IMU (1 deg/hr gyroscopes and 5 micro g accelerometers Bias in-run stability)
- Fluxgate gyro-compensated compass to maintain free-inertial Heading (INS-P model)
- Single and Dual antenna GNSS receivers (NovAtel, uBlox)
- Compatibility with LiDARs (Velodyne, RIEGL, FARO) and optical cameras
- Odometer, Wheel sensor, Airspeed sensor, Wind sensor, Doppler shift from locator aiding data
- 1 cm + 1 ppm RTK Horizontal Position Accuracy or 2.5 cm TerraStar-C PRO Horizontal Position Accuracy
- 0.05 deg GNSS Heading and <0.4 deg Free-inertial Heading accuracy (3 sigma)
- Advanced, extendable, embedded Kalman Filter based sensor fusion algorithms
- State-of-the-art algorithms for different dynamic motions of Vessels, Ships, Helicopters, UAV, UUV, UGV, AGV, ROV, Gimbals and Land Vehicles
- Implemented ZUPT, GNSS tracking angle features
- Full temperature calibration, Environmentally sealed (IP67), compact design, MIL-STD-810G/DO-160E

WAYPOINT
PRODUCTS GROUP

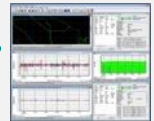

ROS



LabVIEW

Models & Features

INS-B



Basic

Ideal solution for remote sensing (UAV, LiDAR, Optical Camera, Point Clouds)

INS-P



Professional

High performance in long-term GPS-Denied environment

INS-D



Dual Antenna

High precision Heading Tactical-grade IMU SP/SBAS/DGPS/RTK

INS-DL



Dual Antenna

High precision Heading Industrial-grade IMU 1 cm RTK position

Parameter	Units	INS-B	INS-P	INS-D	INS-DL
GENERAL					
Output signals		<ul style="list-style-type: none"> Positions, Heading, Dual antenna Heading (D/DL), Pitch, Roll, Velocity, Accelerations, Angular rates, Barometer, PPS Direct AT_ITINS message with Position, Heading, Pitch & Roll to COBHAM AVIATOR UAV 200 Direct Navigation Support for Pixhawk Flight Controllers as NMEA messages 			
Input signals		<ul style="list-style-type: none"> Marine application: DVL (Doppler Velocity Log) Land application: Odometer, Wheel sensor, Encoder, DMI Aerial application: Wind sensor, Air Speed Sensor, Doppler shift from locator (for long-term GPS denied) All: External Stand-Alone Magnetic Compass (SAMC/AHRS) 			
Main features		Ideal solution for remote sensing (with LIDAR, Optical Camera)	High performance in long-term GPS-Denied environment	High precision Heading Tactical-grade IMU	Affordable price High precision Heading 1 cm RTK position
Compatible with		Pixhawk Autopilot; Embention Autopilot; COBHAM AVIATOR UAV 200			
Data rate	Hz	Up to 200 (INS data); Up to 2000 (IMU data)			Up to 200 (INS) & 2000 (IMU)
Internal Data Logger (storage) - optional		64 GB			64 GB
Start-up time	sec	<1			<1
Navigation					
Positions and Velocity					
Horizontal position accuracy (GPS L1)	meters, RMS		1.5		1.5
Vertical position accuracy (GPS L1)	meters, RMS		<1		<2
Horizontal position accuracy (GPS L1/L2)	meters, RMS		1.2		1.2
Horizontal position accuracy (SBAS) ⁽¹⁾	meters, RMS		0.6		0.6
Horizontal position accuracy (DGPS)	meters, RMS		0.4		n/a
Horizontal position accuracy (TerraStar-L) ⁽²⁾	meters, RMS		0.4		n/a
Horizontal position accuracy (TerraStar-C PRO) ⁽²⁾	meters, RMS		0.025		n/a
Horizontal position accuracy (TerraStar-X) ⁽²⁾	meters, RMS		0.02		n/a
Horizontal position accuracy (post-processing) ⁽³⁾	meters, RMS		0.005		0.005
Horizontal position accuracy (RTK)	meters, RMS		0.01 + 1 ppm		0.01 + 1 ppm CEP
Vertical position accuracy (RTK)	meters, RMS		0.02		0.02 + 1ppm CEP
Position accuracy (free inertial, land vehicles) ⁽⁴⁾	% , DT	0.2% DT (using Tunnel Guide positional aiding references)			0.5% DT (using Tunnel Guide positional aiding references)
Velocity accuracy, RMS	m/s RMS				0.03
Heading					
Range	deg	0 to 360	0 to 360	0 to 360	
Static Accuracy ⁽⁵⁾	deg RMS	1	0.3	Novatel OEM7720 / Dual Mosaic X5 0.15 (1 meter baseline) 0.08 (2 meters baseline)	
Dynamic accuracy (GNSS) ⁽⁶⁾	deg RMS	0.1	0.1	Dual uBlox ZED-F9P 0.4 (1 meter baseline) 0.2 (2 meters baseline)	
Post processing accuracy ⁽³⁾	deg RMS	0.03	0.03	0.03	0.1
Pitch and Roll					
Range: Pitch, Roll	deg	±90, ±180			±90, ±180
Angular Resolution	deg	0.01			0.01
Static Accuracy in whole Temperature Range	deg RMS	0.05			0.08
Dynamic Accuracy ⁽⁶⁾	deg RMS	0.03			0.04
Post processing accuracy ⁽³⁾	deg RMS	0.006			0.01
Gyroscopes					
Type		Tactical-grade			Industrial-grade
Measurement range	deg/sec	±450 / ±950			±450 / ±950
Bias in-run stability (RMS, Allan Variance)	deg/hr	1			3
Bias error over temperature range (RMS)	deg/hr	<30			<50
Angular Random Walk	deg/√hr	<0.2 (0.08 optional)			<0.3
Accelerometers					
Type		Tactical-grade			Industrial-grade
Measurement range	g	±8 g / ±15 g / ±40 g			±8 g ±15 g ±40 g
Bias in-run stability (RMS, Allan Variance)	mg	0.005 (±8 g) / 0.02 (±15 g) / 0.03 (±40 g)			0.01 0.03 0.05
Bias error over temperature range (RMS)	mg	0.5 (±8 g) / 0.7 (±15 g) / 1.2 (±40 g)			0.7 1.1 1.5
Bias one-year repeatability	mg	1.0 (±8 g) / 1.3 (±15 g) / 1.5 (±40 g)			1.5 2.0 2.5
Velocity Random Walk	m/s/√hr	0.015 (±8 g) / 0.035 (±15 g) / 0.045 (±40 g)			0.02 0.045 0.06
Magnetometers					
Measurement range	Gauss	Optional			Optional
Bias in-run stability, RMS	nT	Optional			Optional
Noise density, PSD	nT/√Hz	Optional			Optional
Pressure					
Measurement range	hPa	300 – 1100			300 – 1100
Bias in-run stability (RMS, Allan Variance)	Pa	2			2
Noise density	Pa/√Hz	0.8			0.8
Environment					
Operating temperature	deg C	-40 to +75			
Storage temperature	deg C	-50 to +85			
MTBF (G ₀ @ +65degC)	hours	100,000			
Shock and Vibration		MIL-STD-810G			
EMC/EMI		MIL-STD-461F			
Electrical					
Supply voltage	V DC	9 to 36 (26±10 for MIL-1275 protection)	9 to 36 (26±10 for MIL-1275 protection)	9 to 36 (26±10 for MIL-1275 protection)	9 to 36 (26±10 for MIL-1275 protection)
Power consumption	Watts	2.5 (3.5 with datalogger)	3.5 (4.5 with data logger)	5 (6 with datalogger)	5 (6 with datalogger)
Output Interface (options)		RS-232 / RS-422 / CAN / Ethernet / 2 x RS-232 / 2 x RS-422 / RS-232 + CAN + Ethernet / RS-422 + CAN + Ethernet			
Protection (optional)		MIL-STD-1275			
Output data format		Binary, NMEA 0183 ASCII characters			
Physical					
Size ⁽⁹⁾	mm	120 x 50 x 53	120 x 50 x 53	120 x 50 x 53	120 x 50 x 53
Weight ⁽⁹⁾	gram	220	280	320	320

⁽¹⁾ GPS only; ⁽²⁾ Requires a subscription to a TerraStar data service ⁽³⁾ RMS, incremental error growth from steady state accuracy. Post-processing results using third party software; ⁽⁴⁾ Under ideal conditions that include proper static alignment and in-field dynamic motions during loss of GNSS signal; ⁽⁵⁾ calibrated in whole operational temperature range, in homogeneous magnetic environment, for latitude up to +65 deg; ⁽⁶⁾ 50 Hz while tracking up to 20 satellites. 20 Hz position update rate for Basic mode of INS; ⁽⁷⁾ dynamic accuracy may depend on type of motion; ⁽⁸⁾ Weight and size are PM dependent. Customers should obtain the most recent 2D/3D files before designing any interface hardware.

Receiver Options Available	Units	Novatel OEM719	Novatel OEM7720	Mosaic X5	uBlox ZED-F9P
Available For	-	INS-B, INS-P	INS-D, INS-DL	INS-B, INS-P, INS-D, INS-DL	INS-B, INS-P, INS-D, INS-DL
Number of GNSS Antennas	-	Single	Dual	Single or Dual	Single or Dual
GNSS Constellations	-	GPS L1 C/A, L1C, L2C, L2P, L5; GLONASS L1 C/A, L2 C/A, L2P, L3, L5; BeiDou B1I, B1C, B2I, B2A, B3I; Galileo E1, E5 AltBOC, E5a, E5b, E6; QZSS L1 C/A, L1C, L2C, L5, L6; NavIC (IRNSS) L5; L-Band	GPS L1 C/A, L1C, L2C, L2P, L5; GLONASS L1 C/A, L2 C/A, L2P, L3, L5; BeiDou B1I, B1C, B2I, B2A, B3I; Galileo E1, E5 AltBOC, E5a, E5b, E6; QZSS L1 C/A, L1C, L2C, L5, L6; NavIC (IRNSS) L5; L-Band	GPS L1C/A, L1C, L1PY, L2C, L2P, L5; GLONASS L1C/A, L2CA, L2P, L3 CDMA; BeiDou B1I, B1C, B2A, B2I, B3; Galileo E1, E5a, E5b, E5 AltBOC, E6; QZSS L1C/A, L1C, L2C, L5, L6; Navic L5; L-band	GPS L1C/A, L2C; GLONASS L1OF, L2OF; Galileo E1B/C, E5b; BeiDou B1I, B2I; QZSS L1C/A, L2C
GNSS Corrections	-	WAAS; EGNOS; MSAS; GAGAN; SBAS L1, L5; DGPS; RTK; PPP Terrastar	WAAS; EGNOS; MSAS; GAGAN; SBAS L1, L5; DGPS; RTK; PPP Terrastar	WAAS; EGNOS; MSAS; GAGAN; SBAS L1, L5; DGPS; RTK	WAAS; EGNOS; MSAS; GAGAN; SBAS L1C/A; DGPS; RTK
Channel Configuration ⁽¹⁾	-	555	555	448	184
GNSS Data Rate ⁽¹⁾	Hz	5 / 20 / 100	5 / 20 / 100	100 (max)	10, 20 ⁽²⁾
RTK Corrections	-	RTCM 2, RTCM 3	RTCM 2, RTCM 3	RTCM 2, RTCM 3	RTCM 3
Velocity Accuracy	m/s	0.03	0.03	0.03	0.05
Initialization Time	s	<39 (cold start), <20 (hot start)	<39 (cold start), <20 (hot start)	<45 (cold start), <20 (hot start)	<30 (cold start), <10 (hot start)
Time Accuracy (clock drift) ⁽³⁾	Nano sec	20	20	20	30

⁽¹⁾ tracks up to 60 L1/L2 satellites; ⁽²⁾ If tracking GPS only; ⁽³⁾ time accuracy does not include biases due to RF or antenna delay

Inertial Labs GPS-Aided INS key sensors (IMU) performance

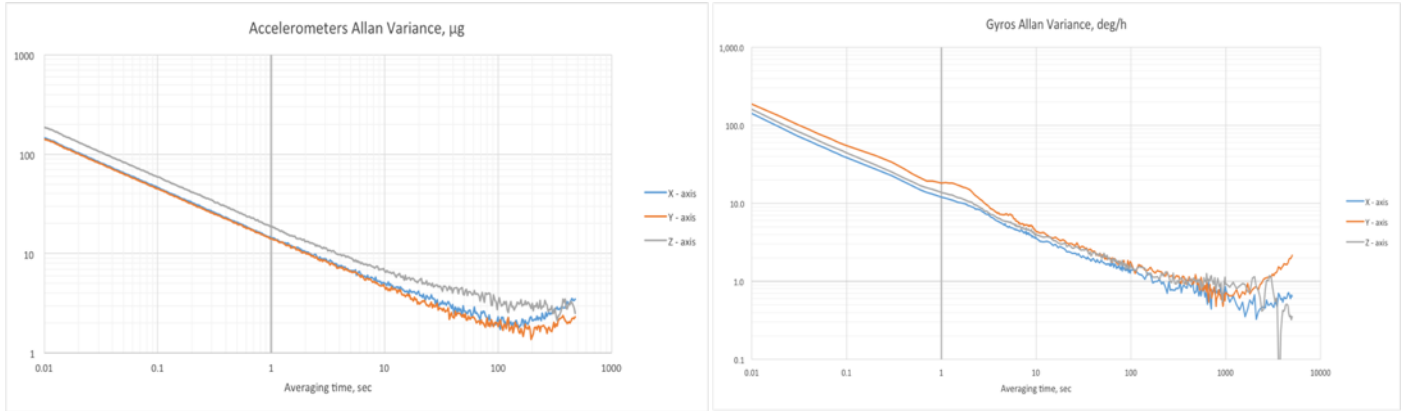

Inertial Labs GPS-Aided INS key applications



INS Product Code Structure

Model	Gyro	Accel	Calibration	Connector & Enclosure	Encoder support	Color	Stand Alone Magnetic Compass	Data Logger	GNSS receiver	Version	Interface
INS-B	G450	A8	TGA	C1 (obsolete)	E (option)	B (default)	SAMC	S64	O615 (obsolete)	V0	1
INS-P	G950	A15	TMGA	C3 (default)		D			O617D (obsolete)	V1	2
INS-D	G2000	A40		C31		G			O718D (China only)	V2	4
INS-DL				C32		W			O719	V3	5
				C35					O7720	V4	11
				C36					B482 (obsolete)	V49	15
				C37					ZD9P	VR43	22
				C5					ZF9P	VR5	23
				C7					SMX5	V8	245
				C71					DMX5	V9	124
									ER	V91	1234
										VD4	1245
										VD42	
										VD44	
										VD43	
										VD49	
										VD9	
										VD91	

Example: INS-B-G450-A8-TGA-C3E-B-S64-O719-V0.1

Product code details:

- INS-B: Basic Model of GPS-Aided Inertial Navigation System
- INS-P: Professional Model of GPS-Aided Inertial Navigation System
- INS-D: Dual Antenna GPS-Aided Inertial Navigation System
- INS-DL: Dual Antenna GPS-Aided Inertial Navigation System
- G450: Gyroscopes measurement range = ± 450 deg/sec
- G950: Gyroscopes measurement range = ± 950 deg/sec
- G2000: Gyroscopes measurement range = ± 2000 deg/sec
- A8: Accelerometers measurement range = ± 8 g
- A15: Accelerometers measurement range ± 15 g
- A40: Accelerometers measurement range ± 40 g
- TGA: Gyroscopes and Accelerometers
- TMGA: Magnetometers, Gyroscopes and Accelerometers (INS-P and INS-D only)
- C1: 12 pins connector (RS-232) - OBSOLETE
- C3: 24 pins connector (RS-232, RS-422, CAN, Ethernet interfaces)
- C31: 24 pins connector (RS-232, 2 x RS-422, CAN interfaces)
- C32: 24 pins connector (RS-232, RS-422, CAN, Ethernet interfaces) with modified PPS (preserve PPS configurable polarity): Active high – 5v (1'). Active low – 0v (0')
- C35: 24 pins connector, Differential PPS, MIL-STD-1275 protection
- C36: 24 pins connector (RS-232, RS-422, CAN, Ethernet interfaces, Trigger (Event) pin #4 of the INS for entering the FW update mode)
- C37: 24 pins connector (RS-232, RS-422, CAN, Ethernet interfaces) and MIL-STD-1275 Protection
- C5: 24 pins connector, flanges and alignment pins
- C7: two 19 pins connectors
- C71: two 19 pins connectors, MIL-STD-1275 protection
- E: encoder support
- B - Black Color (default)
- D - Desert Color (Desert tan, color code 33446 (tan 686A) per FED-STD-595, Change Notice 1.)
- G - Green
- W - White
- SAMC – Support external Stand-Alone Magnetic Compass (optional) (can only be used with VX.1234)
- S64: 64GB embedded Data Logger (optional)
- O615: Novatel OEM615 single antenna GNSS receiver (INS-B and INS-P only) - OBSOLETE
- O617D: Novatel OEM617D dual antenna GNSS receiver (INS-D only) - OBSOLETE
- O718: Novatel OEM718D dual antenna GNSS receiver (INS-D, for China only)
- O719: Novatel OEM719 single antenna GNSS receiver (INS-B and INS-P only)
- O7720: Novatel OEM7720 dual antenna GNSS receiver (INS-D only)
- B482: Inertial Labs B482 dual antenna GNSS receiver OBSOLETE
- ZD9P: Dual ZED-F9P, Dual-Frequency, Multi-Constellation, RTK Capable GNSS Receiver
- ZF9P: Single ZED-F9P, Dual-Frequency, Multi-Constellation, RTK Capable GNSS Receiver (INS-B, and INS-P only)
- SMX5: Single Mosaic X5 GNSS Receiver (INS-B and INS-P only)
- DMX5: Dual Mosaic X5 GNSS Receiver (INS-D and INS-DL only)
- ER: Support External GNSS receiver. External GNSS receiver must provide GGA and RMC messages (optionally HDT)
- V0: GPS L1, SBAS, DGPS, 20 Hz positions (NovAtel Single Antenna GNSS Receiver only)
- V1: GPS L1, SBAS, DGPS, 50 Hz positions (NovAtel Single Antenna GNSS Receiver only)
- V2: GPS L1, GLONASS, SBAS, DGPS, 20 Hz positions (NovAtel Single Antenna GNSS Receiver only)
- V3: GPS L1/L2, SBAS, DGPS, 20 Hz positions (NovAtel Single Antenna GNSS Receiver only)
- V4: GPS L1/L2, GLONASS L1/L2, SBAS, DGPS, 20 Hz positions (NovAtel Single Antenna GNSS Receiver only)
- V49: GPS L1/L2, GLONASS L1/L2, NavIC (IRNSS), SBAS, DGPS, 20 Hz GNSS positions (NovAtel Single Antenna GNSS Receiver only)
- VR43: GPS L1/L2, GLONASS L1/L2, SBAS, DGPS, 20 Hz positions, 20 Hz measurements (NovAtel Single Antenna GNSS Receiver only)
- VR5: GPS L1/L2, GLONASS L1/L2, SBAS, DGPS, RTK, 20 Hz positions, 20 Hz measurements (NovAtel Single Antenna GNSS Receiver only)
- V8: GPS L1/L2/L5, GLONASS L1/L2, BeiDou B1/B2/B3, GALILEO E1/E5; SBAS; DGPS; 20 Hz measurements; 20 Hz positions RTK (NovAtel Single Antenna GNSS Receiver only)
- V9: GPS L1/L2, GLONASS L1/L2, BEIDOU B1/B2, GALILEO E1/E5, QZSS L1/L5, DGPS, RTK, GNSS measurements, GNSS positions (Single Antenna GNSS Receiver only)
- V91: GPS L1/L2/L5, GLONASS L1/L2/L3, GALILEO E1/E5/E6, BEIDOU B1/B2/B3, NavIC L5, SBAS, RTK, GNSS measurements, GNSS positions (Single Antenna Mosaic X5 Receiver only)
- VD4: GPS L1/L2, Dual antenna Heading, SBAS, DGPS, 20 Hz positions (NovAtel Dual Antenna GNSS Receiver only)
- VD42: GPS L1/L2, GLONASS L1/L2, Dual antenna Heading, SBAS, DGPS, RTK, 20 Hz measurements, 20 Hz positions (NovAtel Dual Antenna GNSS Receiver only)
- VD43: GPS L1/L2, GLONASS L1/L2, Dual antenna Heading, SBAS, DGPS, 20 Hz positions (NovAtel Dual Antenna GNSS Receiver only)
- VD44: GPS L1/L2, GLONASS L1/L2, GALILEO E1/E5, Dual antenna Heading, SBAS, DGPS, 20 Hz positions (NovAtel Dual Antenna GNSS Receiver only)
- VD49: GPS L1/L2, GLONASS L1/L2, NavIC (IRNSS), Dual antenna Heading, SBAS, DGPS, 20 Hz positions; 20 Hz GNSS measurements (NovAtel Dual Antenna GNSS Receiver only)
- VD9: GPS L1/L2, GLONASS L1/L2, BEIDOU B1/B2, GALILEO E1/E5, QZSS L1/L5, DGPS, RTK, Dual antenna Heading, GNSS measurements, GNSS positions (Dual Antenna GNSS Receiver only)
- VD91: GPS L1/L2/L5, GLONASS L1/L2/L3, GALILEO E1/E5/E6, BEIDOU B1/B2/B3, NavIC L5, SBAS, RTK, Dual Antenna Heading, GNSS measurements, GNSS positions (Dual Antenna Mosaic X5 Receiver only)
- VX.1: RS-232 interface
- VX.2: RS-422 interface
- VX.4: CAN interface
- VX.5: Ethernet interface
- VX.11: two RS-232 interfaces
- VX.15: RS-232 and Ethernet interfaces
- VX.22: two RS-422 interfaces
- VX.23: RS-422, RS-485 (to be used when connecting to a Stand-alone Magnetic Compass)
- VX.245: RS-422, CAN and Ethernet interfaces (w/o Encoder support)
- VX.124: RS-232, RS-422 and CAN interface.
- VX.1234: RS-232, RS-422, RS-485 (to be used when connecting to a Stand-alone Magnetic Compass), and CAN interface.
- VX.1245: RS-232, RS-422, CAN and Ethernet interface.

IMU Center Diagram

ppm GmbH
Grube 39a
82377 Penzberg
Germany
Tel: +49 (0) 88 56 8 03 09 80
Fax: +49 (0) 88 56 8 03 09 88
info@ppmgmbh.com
www.ppmgmbh.com

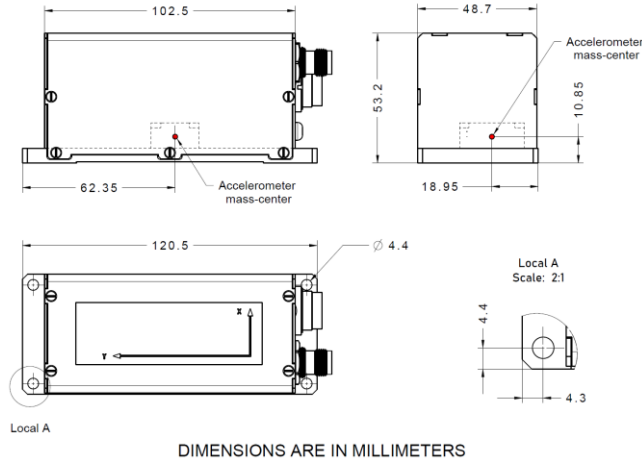

All dimensions within this drawing are subject to change without notice. Customers should obtain final drawings before designing any interface hardware.

Default: INS-D / INS-DL mechanical interface drawing

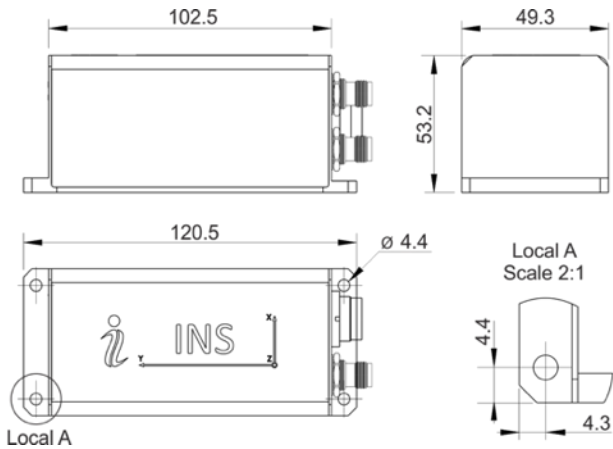

Default: INS-B / INS-P mechanical interface drawing

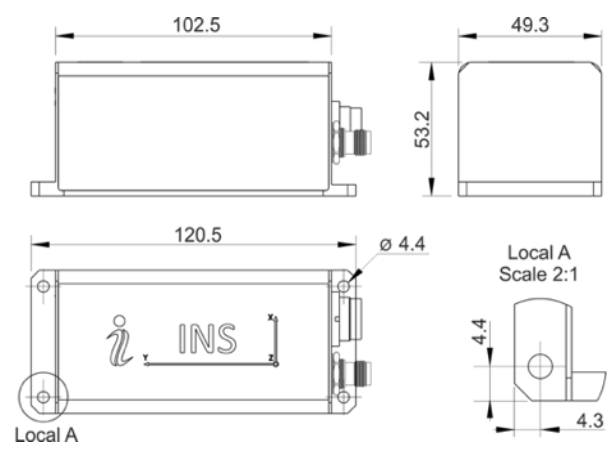

Optional: INS-D / INS-DL with alignment pins

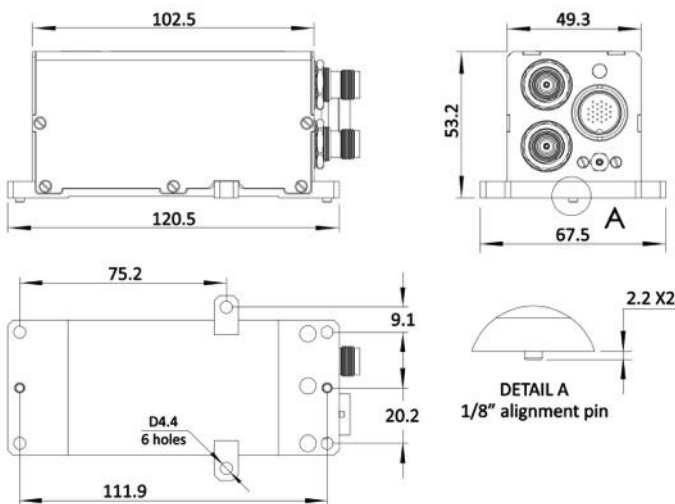

Optional: INS-B / INS-P with alignment pins

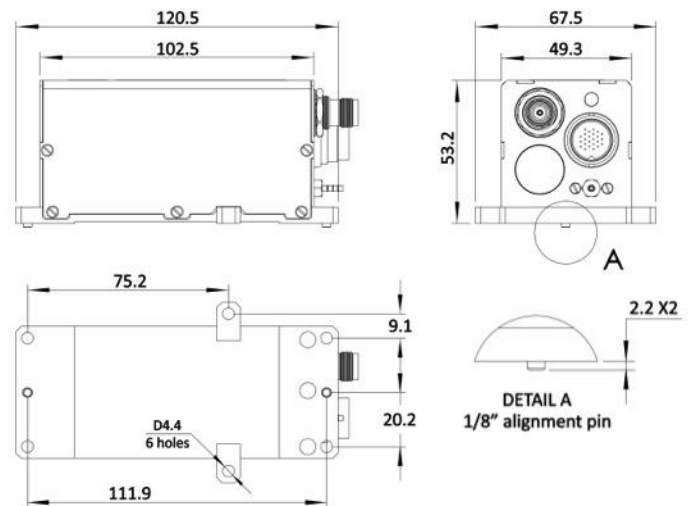

1. All dimensions are in millimeters.
2. All dimensions within this drawing are subject to change without notice. Customers should obtain final drawings before designing any interface hardware.
3. Interface connector type: Binder. Male receptacle, shielded, rear-mounting
4. GNSS antenna connector type: TNC - Female