



# XXATTENPDC

## Fixed Attenuator XX dB Technical Product Data

### Features

---

- Custom Attenuation Level
  - Set the attenuation from 0 - 30dB
- Small Form Factor
  - 2.5 x 0.75 x 0.875 in (Not Including Connectors).
- Extremely Flat Group Delay
  - Less that 1ns variation
- Excellent Flatness
  - Attenuation | L1 – L2 | < 1.0 dB
- Low SWR < 2.0:1 maximum



### Description

---

This **1 to 30 dB Fixed Attenuator Pass DC (XXATTENPDC)** is a one input, one output attenuator optimized for GPS applications. This equipment accepts signals covering all major GNSS constellations with excellent flatness. In the standard configuration, the J1 port accepts DC voltage from a connected GPS receiver. This unregulated voltage is passed through the antenna port to power a connected active antenna or other upstream devices.

### Use Cases

- Can be used to reduce the power of amplified signals for optimal compatibility with sensitive GNSS receivers.
- Can be used to increase isolation and return loss for a subsection of a GNSS distribution network.





# XXATTENPDC

## Electrical Specifications, TA=25°C

### General Specification

Parameter	Notes	Min	Typ	Max	Unit
Frequency Range	Covers all major GNSS constellations.	1.1		1.7	GHz
Characteristic Impedance	Input and output ports matched to 50Ω.		50		Ω
Acceptable DC Input Voltage	Operating Voltage Range.	0		35	VDC
Current Handling	Maximum current that can be passed through the device.			400	mA

### GPS L1 & L2 RF Specification <sup>(1)</sup>

Parameter	Notes	Min	Typ	Max	Unit
Attenuation	The relative decrease in signal power provided by the attenuator. Specified value between 1 and 30 (X).	X-1	X	X+1	dB
Input SWR	Input Standing Wave Ratio: S11 at L1 and L2		1.7:1	2.0:1	-
Output SWR	Output Standing Wave Ratio: S22 at L1 and L2		1.7:1	2.0:1	-
Band Attenuation Flatness	The difference in loss or gain between the L1 and L2 frequencies.		0.5	1	dB

(1): Performance may be slightly reduced around GPS L5. If working on sensitive L5 applications, please request performance data.

Pass/Block DC Options		
	ANTENNA PORT	J1 PORT
PDC – Pass DC – XXATTENPDC	DC THRU	DC THRU
BDC – Block DC – XXATTENBDC	DC BLOCKED	DC THRU
Connector Options	Connector Style	Charge
	Type N-female	No Charge
	Type SMA-female	No Charge
	Type TNC-female	No Charge
	Type BNC-female	No Charge
	Other	Contact GPS Networking



# XXATTENPDC

## Part Number Configuration

---

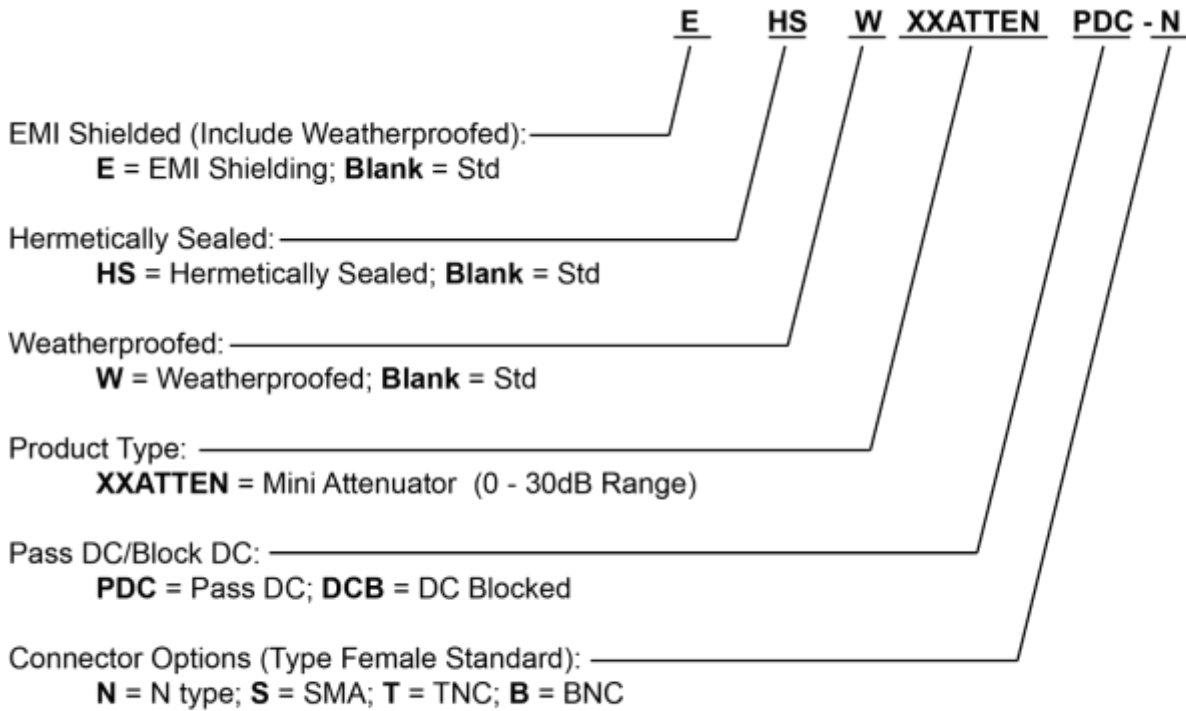

Contact GPS Networking Technical Support at 1-800-463-3063 or [salestech@gpsnetworking.com](mailto:salestech@gpsnetworking.com) for any questions regarding non-standard configurations and corresponding part numbers.



# XXATTENPDC

## Performance

### XXATTENPDC

Each XXATTENPDC ships with a test sheet that verifies critical performance characteristics, such as gain, input VSWR, and amplitude balance; a typical VNA test sheet is shown below.

### GPS NETWORKING Test Data

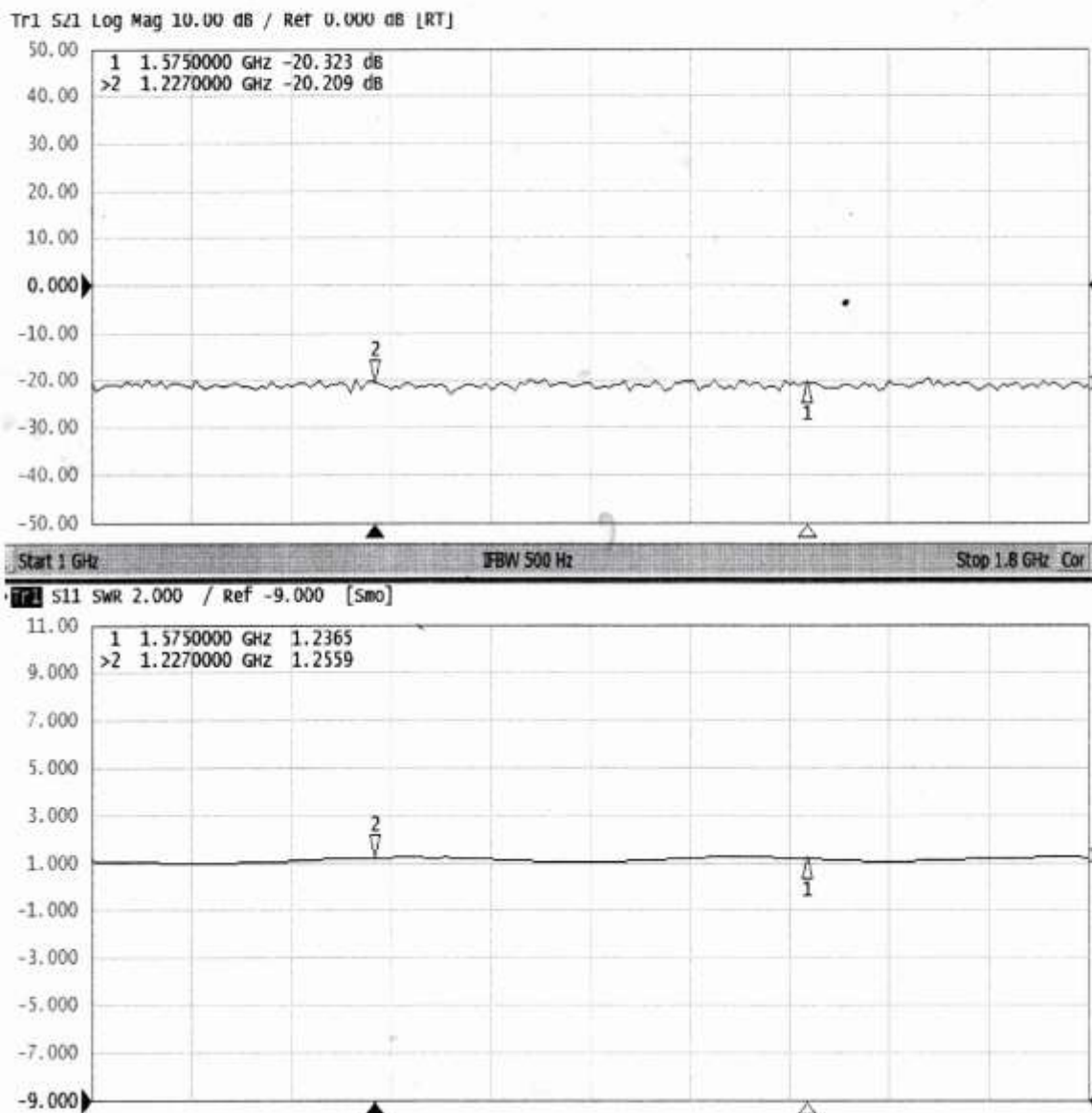

# Mechanical

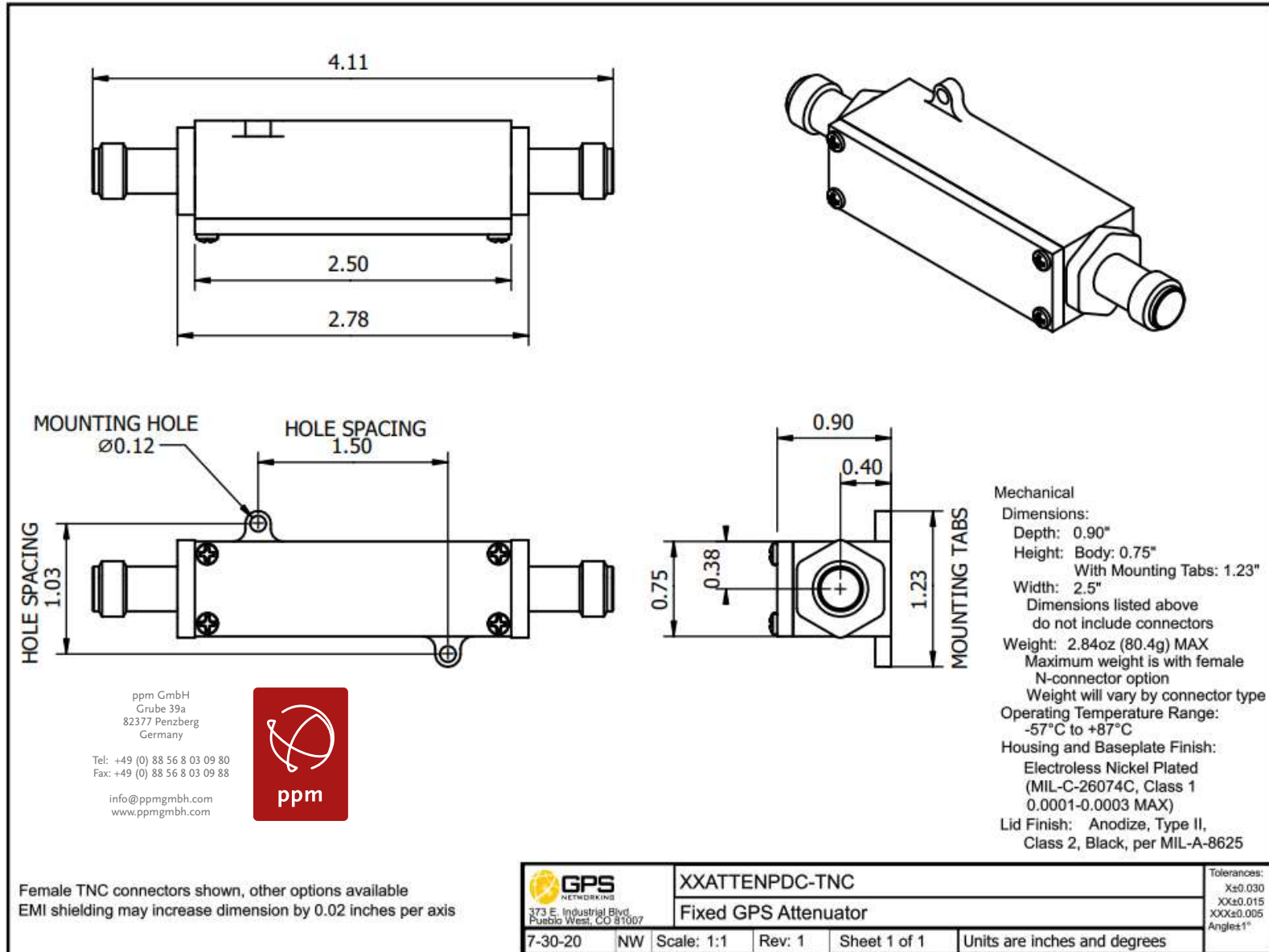

Contact us at [salestech@gpsnetworking.com](mailto:salestech@gpsnetworking.com) for 3D models or CAD drawings.