



G5ANT-42XXX ANTENNA FAMILY

ARINC Footprint GNSS Antenna

The G5Ant-42XXX product family is a multi-frequency antenna for assured Global Navigation Satellite Signal (GNSS) signal reception. This Antcom “G5” antenna operates in five frequency bands and includes support for GLONASS L1, GPS L1, L-Band, GLONASS L2, and GPS L2. The baseplate is designed to be compatible with ARINC 743 mounting hole and footprint requirements. An O-ring seal between the antenna and your platform ensures easy installation.

The product family is offered in passive and active (amplified) configurations. The active configurations offer 2-stage integrated bandpass filtering for high out-of-band rejection, and limiter diodes to protect sensitive receiver electronics. The passive configurations are best suited to applications where the antenna is located close to the GNSS receiver and offer the lowest insertion loss for minimizing the noise figure of your system.

Antcom is able to customize this product family to meet your specific requirements. Please contact us for more information about customization options.

BENEFITS

- Easy design into new platforms or retrofit into existing platforms
- Multi-frequency GNSS coverage to support precision applications

FEATURES

- Multi-frequency, multi-constellation for assured GNSS reception
- ARINC 743 compatible mounting holes and footprint
- Passive or active (amplified) configurations available
- DC power input through RF connector
- Connector options available
- Paint color options available



OPTIONS

- | | |
|-----------|--|
| COLOR | <ul style="list-style-type: none">• Gloss White• Lusterless Gray• Camo Green• Lusterless Black• Desert Tan |
| CONNECTOR | <ul style="list-style-type: none">• SMA• MCX• MMCX• Type N• TNC |
| LNA GAIN | <ul style="list-style-type: none">• With 33 dB LNA• With 40 dB LNA• Without LNA |

ELECTRICAL

Frequency Range:	
L2 GPS	1227.60 ± 12 MHz
L2 GLONASS	1242 -1249 MHz
L-Band	1545 -1610 MHz
B1 BeiDou	1561.098 ± 10 MHz
L1 GPS	1575.42 ± 15.0 MHz
E1 Galileo	1575.42 ± 17.0 MHz
L1 GLONASS	1609 ± 7.0 MHz
VSWR	<2.0:1
Impedance	50 ohms
Polarization	RHCP

MECHANICAL & ENVIRONMENTAL

Designed to:

Weight	8.14 oz Typical
Temperature	-55°C to +85°C
Altitude	70,000 ft
Vibration	>30 Grms

TYPICAL LNA PERFORMANCE

LNA Gain	See Options Table
LNA Noise Figure	3.5 dB
LNA P1dB Out	+13 dBm
LNA DC Power	(3.8 - 15) V <70 mA

LIMITING & FILTERING

Power Handling	1 Watt CW
-----------------------	-----------



ppm GmbH
Grube 39a
82377 Penzberg
Germany

Tel: +49 (0) 88 56 8 03 09 80
Fax: +49 (0) 88 56 8 03 09 88

info@ppmgmbh.com
www.ppmgmbh.com

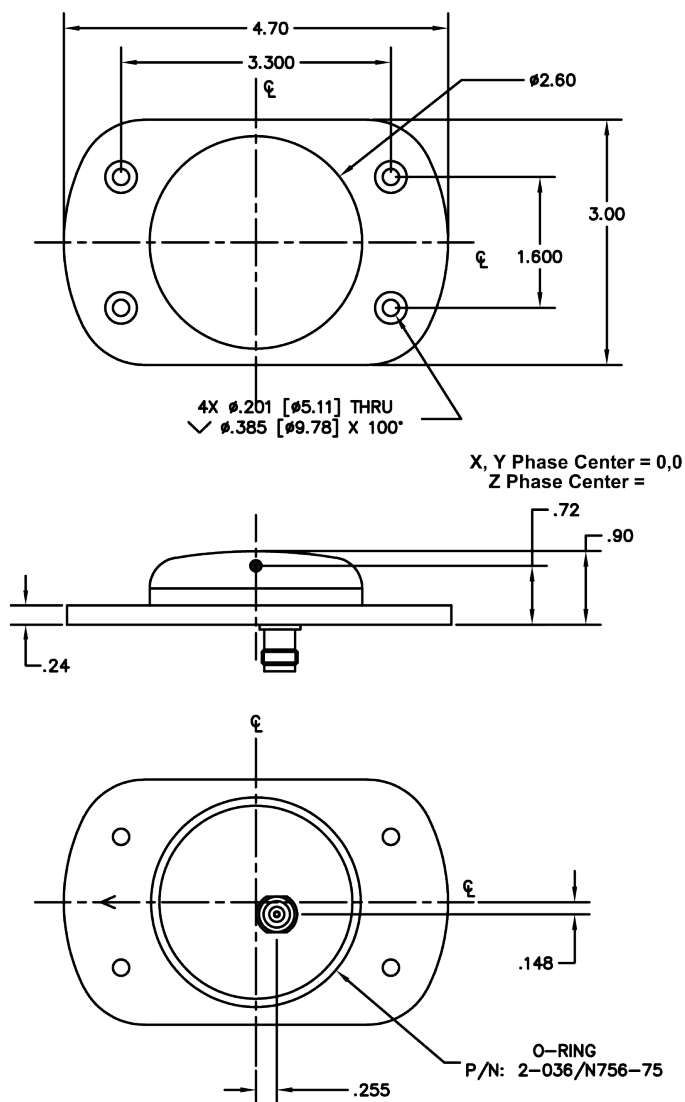

PART NUMBER DECODER

G5Ant-42XXX

LNA Gain

- A = With 33 dB
- A4 = With 40 dB
- P = Passive

Color (PER AMS-STD-595)

- 1 = Gloss White #17925
- 2 = Lusterless Gray #36320
- 3 = Camo Green #34094
- 4 = Lusterless Black #37038
- 5 = Desert Tan #33446

Connector

- S = SMA
- M = MCX; MM=MMCX
- N = Type N; NB = N-Bulkhead
- T = TNC; TB = TNC-Bulkhead

CONTACT ANTCOM

Phone: +1-310-782-1076
Fax: +1-310-782-1086
Email: sales.pi.antcom@antcom.com
Web: antcom.com

